

# BELT DRIVE TUBEAXIAL ROOF EXHAUSTER

## FEATURES:

- HEAVY GAUGE STEEL CONSTRUCTION
- BUTTERFLY DAMPERS
- ALUMINUM AIRFOIL PROPELLER
- DISCONNECT SWITCH
- PILLOW BLOCK BEARINGS

## OPTIONS

- ROOF CURBS
- OUTLET GUARD
- INSPECTION DOOR
- MAGNETIC LATCHES

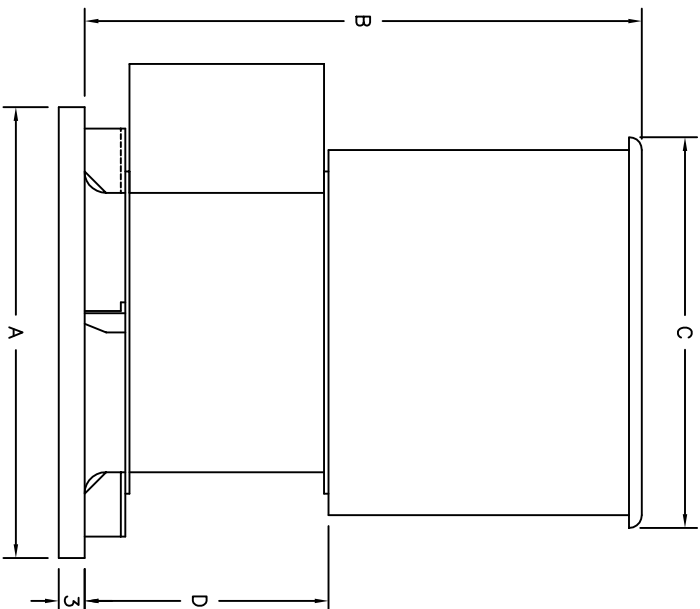

RPTUB - FAN (UL705) DIMENSIONAL DATA

FAN MODEL	A	B	C	D	R0	WEIGHT
RPTUB24	35	55 1/2	30	30 1/2	31	500
RPTUB30	41	58 1/2	36	30 1/2	37	600
RPTUB36	47	60 1/2	42	30 1/2	43	1000
RPTUB42	53	65 1/2	48	32 1/2	49	1100
RPTUB48	59	68 1/2	54	32 1/2	55	1300
RPTUB54	65	71 1/2	60	32 1/2	61	1580
RPTUB60	71	74 1/2	66	32 1/2	67	1700

RPTU  
REV.#0 06/16/201

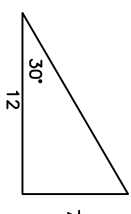
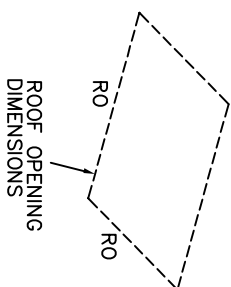
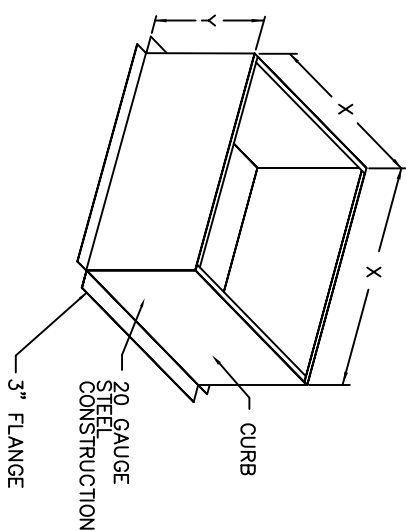

PITCHED CURBS ARE AVAILABLE FOR PITCHED ROOFS.

SPECIFY PITCH:  
EXAMPLE: 7/12 PITCH = 30° SLOPE

CURB DIMENSIONAL DATA

FAN MODEL	X	Y
RPTUB24	33-1/4	12
RPTUB30	39-1/4	12
RPTUB36	45-1/4	12
RPTUB42	51-1/4	12
RPTUB48	57-1/4	12
RPTUB54	63-1/4	12
RPTUB60	69-1/4	12