



DESIGN GUIDE & PRODUCT SPECIFICATIONS

DOUBLE-WALL DUCTWORK



FACTORY-WELDED GREASE DUCT SYSTEM

Table of Contents

4	Overview	26	DW Clamp Assembly
5	Standards and Key Words	28	DW Tee Assembly
6	Specifications	30	DW Y Assembly
7	Table 1 - 3M Fire Barrier 200 Plus Usage	32	DW Fire Stop Assembly
7	Clearances	34	DW Adjustable Assembly
7	Table 2 - Insulation and Clearances	36	DW Adjustable Assembly (Used with TP)
8	Duct Design	38	DW End Cap Assembly
8	Types of Pressure Losses or Resistance to Flow	40	DW Straight Duct Assembly
9	Table 3 - Required Air and Duct Values & Formulas	42	DW Adapter Assembly
9	Nomenclature	44	DW Eccentric Assembly
9	Table 4 - Nomenclature	46	DW Square to Round Adapter
10	Dynamic Loss Coefficient	48	Horizontal Duct Run
10	Table 5 - Dynamic Loss Coefficient Table	50	Vertical Duct Run
11	Design Considerations	52	Appendix A
11	Table 6 - Minimum Overlap	53	Duct Diameter Sizing Charts
12	Alignment and Bracing of a Grease Duct	63	Grease Duct Field Sheet
12	Table 7 - Horizontal Support Spacing		
12	Table 8 - Vertical Support Spacing		
13	Duct Diameter Sizing		
14	DW Offset Assembly 1 Degree		
16	DW Offset Assembly 2 Degree		
18	DW Angle 30 Degree		
20	DW Angle 45 Degree		
22	DW Angle 90 Degree		
24	DW Access Door Assembly		

Overview

Grease duct is ETL listed with a double-wall construction made from 430 stainless steel. Duct diameters range from 8" to 24", with multiple lengths and accessories available. Grease duct is ideal for use in kitchen ventilation applications and is available as a stand-alone system or part of a fully integrated package. Grease duct is pre-engineered for optimum performance for exhaust fans and hoods.

Double wall grease duct is ETL listed to Standard UL-1978 and UL-2221; Grease duct does not have to be welded in the field.

The purpose of the NFPA-96 Standard is to reduce the potential fire hazard of cooking operations, independent of the type of cooking equipment used and whether used in public or private facilities. Please refer to Chapter 7 of the NFPA-96 Standard, Exhaust Duct Systems, for detailed description of duct requirements and design.

All dimensions shown in American Standard (feet and inches).

Standards and Key Words

UL-1978 - Test Standard for Safety Grease Ducts.

UL- 2221 - Test Standard for Double Wall Grease Duct

NFPA-96 - Standard for Ventilation Control and Fire Protection of Commercial Cooking Operations.

ETL - Edison Testing Laboratory, <http://www.intertek-etlsemko.com>. The ETL Listed Mark is the legal equivalent of the UL Listed and CSA Listed Marks throughout the United States and Canada. ETL is a Nationally Recognized Testing Laboratory (NRTL) designated by the Occupational Safety and Health Administration (OSHA).

Access Panel - A closure device used to cover an opening into a duct, an enclosure, equipment, or an appurtenance.

Authority Having Jurisdiction (AHJ) - An organization, office, or individual responsible for enforcing the requirements of a code or standard, or for approving equipment, materials, an installation, or a procedure.

Combustible Material - A material capable of undergoing combustion.

Factory-Built Grease Duct Enclosures - A listed factory-built grease duct system evaluated as an enclosure system for reduced clearances to combustibles and as an alternative to a duct with its fire-related enclosure.

Grease Duct - A containment system for the transportation of air and grease vapors that is designed and installed to reduce the possibility of the accumulation of combustible condensation and the occurrence of damage if a fire occurs within the system.

Grease Tight - Constructed and performing in such a manner as not to permit the passage of any grease under normal cooking conditions.

Fire Wall - A wall separating buildings or subdividing a building to prevent the spread of the fire, and having a fire resistance rating and structural stability.

Non-combustible Material - A material not capable of supporting combustion.

Thermal Expansion - The tendency of matter to increase in volume or pressure when heated.

References - NFPA-96, Standard for Ventilation Control and Fire Protection of Commercial Cooking Operations, 2014 Edition.

Specifications

Furnish double-wall, factory built, grease duct for use with Type 1 kitchen hoods, which conforms to the requirements of NFPA-96. Products shall be ETL listed to UL-1978 and UL-2221 for venting air and grease vapors from commercial cooking operations as described in NFPA-96.

The duct's wall shall be constructed of 430 stainless steel and be available in diameters 8" through 24".

Grease duct shall have one of the manufacturer's listed insulation options and a finished outer stainless steel shell factory installed.

All welds on inner duct shall be dye tested at the factory to expose holes, if applicable. Holes are tested and resealed until duct is effectively sealed. All welds shall be painted for better aesthetics and corrosion prevention.

All supports, fan adapters, hood connections, fittings and expansion joints required to install grease duct shall be included.

Roof penetrations shall comply with listed clearance to combustibles (see Table 2 guide for details). The grease duct will terminate at the fan adapter plate, will be fully welded to the fan adapter plate, and the fan adapter plate will be fastened to the curb using a suitably sized fastener provided by the others (see "Operation, Installation, and Maintenance Manual [OIM]" for details).

Grease duct joints shall be held together by means of formed V bands and sealed with 3M Fire Barrier 2000+. Screws used to secure the vee bands shall be of the hex-head type with flanged stops and tapered "lead in" threads for easy starting. Nuts shall be retained by means of a free-floating cage to allow easy alignment.

Double-Wall Grease Duct shall be installed in accordance with the manufacturer's "Operation, Installation, and Maintenance Manual [OIM]", ETL listing, and state and local codes.

Grease duct installed outside of the building shall be protected against accidental damage or vandalism and should have the outer shell sealed to prevent the insulation from coming in contact with the elements.

Vertical duct shall be supported from the building structure using rigid structural supports. Anchor supports to the structure by welding or bolting steel expansion anchors or concrete inserts. Support horizontally installed grease duct from the building structure using above method or use Duct Mate, Wire Rope & Clutchers, part numbers WR20 & CL20. Saddles and 1/2" threaded rod may also be used for the support of horizontal grease duct.

The joint sealant used to seal all joint assemblies is a 3M product. 3M Fire Barrier 2000+ Silicone Sealant is a ready-to-use, gun-grade, one-component silicone elastomer that cures upon exposure to atmospheric humidity to form a flexible seal. When installed properly, the sealant will control the spread of fire before, during and after exposure to flames. No sealant substitutes may be used. Refer to **Table 1** for information on 3M Fire Barrier coverage.

TABLE 1 - 3M FIRE BARRIER 2000 PLUS USAGE

Duct Diameter	Duct Perimeter	Average Feet Per Tube	Number of Joints Per Tube
8"	2.16'	30	7
10"	2.68'	30	6
12"	3.21'	30	5
14"	3.73'	30	4
16"	4.25'	30	3.5
18"	4.78'	30	3
20"	5.30'	30	3
22"	5.83'	30	2.5
24"	6.35'	30	2.5

Clearances

Double-wall grease duct is primarily intended for use in applications where clearance to combustible materials is critical or where fire wrapping, single-wall duct is not feasible. Three insulation options exist for double-wall duct; each option is listed in **Table 2** with its respective clearances. Insulation and outer shell are factory installed, improving consistency and quality of the ductwork. This duct requires no further insulation after installation and, as a result, usually requires only one onsite inspection.

TABLE 2 - INSULATION AND CLEARANCES

Duct Diameter	Inner Diameter	Outer Diameter	Clearance to Combustibles	Clearance from tip of V band to Combustibles	Clearance to Non-Combustibles
DW-2R	8"-16"	ID + 4	3/4"	0"	0"
DW-3R	8"-24"	ID + 6	3/4"	0"	0"
DW-3Z	8"-24"	ID + 6	0"	0"	0"

Duct Design

Types of Pressure Losses or Resistance to Flow

Total pressure loss is a combination of static and dynamic pressure loss in a duct fitting. It is important to calculate total pressure loss as opposed to only static pressure loss, as dynamic pressure losses are a significant portion of total pressure loss.

Pressure loss in duct work has three components: component pressure losses (in duct-mounted equipment), dynamic pressure losses (in fittings) and frictional pressure losses (along duct walls):

Component Pressure Losses - Due to physical items with known pressure drops, such as hoods, filters, louvers, or dampers.

Dynamic Pressure Losses - Dynamic losses are the result of changes in direction and velocity of air flow. Dynamic losses occur whenever an air stream makes turns, diverges, converges, narrows, widens, enters, exits, or passes dampers, gates, orifices, coils, filters, or sound attenuators. Velocity profiles are reorganized at these places by the development of vortices that cause the transformation of mechanical energy into heat. The disturbance of the velocity profile starts at some distance and is usually assumed to be no shorter than six duct diameters for a straight duct. Dynamic losses are proportional to dynamic pressure and can be calculated using the equation:

$$\text{Dynamic Loss Static Pressure} = (\text{Loss Coefficient}) * (\text{Velocity Pressure})$$

Where the local loss coefficient, known as a C-coefficient, represents flow disturbances for particular fittings or for duct-mounted equipment as a function of their type and ratio of dimensions. Coefficients can be found in this document or the ASHRAE Fittings Diagrams Database.

A local loss coefficient can be related to different velocities; it is important to know which part of the velocity profile is relevant. The relevant part of the velocity profile is usually the highest velocity in a narrow part of a fitting cross section or a straight/branch section in a junction.

Frictional Pressure Losses

Frictional losses in duct sections are a/the result from air viscosity and momentum exchange among particles moving with different velocities. These losses also contribute negligible losses or gains in air systems unless there are extremely long duct runs or there are significant sections using flex duct.

$$\text{Friction Loss Static Pressure} = (0.195 * (\text{Center Line Distance} / \text{Diameter}) * (\text{Velocity Pressure}))$$

Total Static Pressure

$$\text{Total Static Pressure} = \text{Friction Loss Static Pressure} + \text{Dynamic Loss Static Pressure}$$

TABLE 3 - REQUIRED AIR AND DUCT VALUES & FORMULAS

Required Air and Duct Values	Formulas
Q = Air Flow Rate, Units = CFM	
D = Duct Diameter, Units = Feet	
A = Duct Cross Sectional Area, Units = Feet Squared	$A = \text{Pi} * (\text{D}/2)^2$
V = Air Velocity, Units = Feet/Minute	$V = \text{Q}/\text{A}$
VP = Velocity Pressure	$\text{VP} = (\text{V}/4005)^2$
L = Center Line Distance, Units = Feet	
C = Dynamic Loss Coefficient	Found in Tables Below
SPF = Frictional Loss Static Pressure	$\text{SPF} = 0.195 * (\text{L}/\text{D}) * \text{VP}$
SPD = Dynamic Loss Static Pressure	$\text{SPD} = \text{C} * \text{VP}$
SPC = Component Loss Static Pressure	
SP = Static Pressure	$\text{SP} = \text{SPF} + \text{SPD} + \text{SPC}$

Nomenclature

Grease duct parts are identified by a part type and part name (below).

TABLE 4 - NOMENCLATURE

Required Air and Duct Values	Formulas
LT = Straight Duct	AD = Access Door
AJD = Adjustable Duct	TEASY = Tee Assembly
AC = Adjustable Clamp for Adjustable Duct	ADIB = Access Door Inside Blank
CLASY = V Clamp Assembly	TEAD = Tee Assembly Access Door
Riser = Riser	ASY = Assembly in 30, 45, and 90
FRISER = Field Riser	ADP = Adapter
RERI = Retaining Ring for Field Riser	VESU = Vertical Support
TP = Transition Plate	SUBR = Horizontal Support Bracket
C2D = Offset Collar	

Dynamic Loss Coefficient

TABLE 5 - DYNAMIC LOSS COEFFICIENT TABLE								
Straight Duct, Adjustable Duct, Riser Dynamic Loss Coefficient Table								
Inner Duct Diameter (Inches)								
Length (Inches)	8	10	12	14	16	18	20	24
4	0.017	0.013	0.011	0.010	0.008	0.006	0.005	0.004
5	0.021	0.017	0.014	0.012	0.010	0.007	0.006	0.005
6	0.025	0.020	0.017	0.014	0.013	0.008	0.008	0.006
7	0.029	0.023	0.019	0.017	0.015	0.010	0.009	0.007
8	0.033	0.027	0.022	0.019	0.017	0.011	0.010	0.008
9	0.038	0.030	0.025	0.021	0.019	0.013	0.011	0.009
10	0.042	0.033	0.028	0.024	0.021	0.014	0.013	0.010
11	0.046	0.037	0.031	0.026	0.023	0.015	0.014	0.011
12	0.050	0.040	0.033	0.029	0.025	0.017	0.015	0.013
13	0.054	0.043	0.036	0.031	0.027	0.018	0.016	0.014
14	0.058	0.047	0.039	0.033	0.029	0.019	0.018	0.015
15	0.063	0.050	0.042	0.036	0.031	0.021	0.019	0.016
16	0.067	0.053	0.045	0.038	0.033	0.022	0.020	0.017
17	0.071	0.057	0.047	0.041	0.035	0.024	0.021	0.018
18	0.075	0.060	0.050	0.043	0.038	0.025	0.023	0.019
19	0.079	0.063	0.053	0.045	0.040	0.026	0.024	0.020
20	0.084	0.067	0.056	0.048	0.042	0.028	0.025	0.021
21	0.088	0.070	0.058	0.050	0.044	0.029	0.026	0.022
22	0.092	0.073	0.061	0.052	0.046	0.031	0.028	0.023
23	0.096	0.077	0.064	0.055	0.048	0.032	0.029	0.024
24	0.100	0.080	0.067	0.057	0.050	0.033	0.030	0.025
25	0.104	0.084	0.070	0.060	0.052	0.035	0.031	0.026
26	0.109	0.087	0.072	0.062	0.054	0.036	0.033	0.027
27	0.113	0.090	0.075	0.064	0.056	0.038	0.034	0.028
28	0.117	0.094	0.078	0.067	0.058	0.039	0.035	0.029
29	0.121	0.097	0.081	0.069	0.061	0.040	0.036	0.030
30	0.125	0.100	0.084	0.072	0.063	0.042	0.038	0.031
31	0.129	0.104	0.086	0.074	0.065	0.043	0.039	0.032
32	0.134	0.107	0.089	0.076	0.067	0.044	0.040	0.033
33	0.138	0.110	0.092	0.079	0.069	0.046	0.041	0.034
34	0.142	0.114	0.095	0.081	0.071	0.047	0.043	0.035
35	0.146	0.117	0.097	0.084	0.073	0.049	0.044	0.036
36	0.150	0.120	0.100	0.086	0.075	0.050	0.045	0.038
37	0.154	0.124	0.103	0.088	0.077	0.051	0.046	0.039
38	0.159	0.127	0.106	0.091	0.079	0.053	0.048	0.040
39	0.163	0.130	0.109	0.093	0.081	0.054	0.049	0.041
40	0.167	0.134	0.111	0.095	0.084	0.056	0.050	0.042
41	0.171	0.137	0.114	0.098	0.086	0.057	0.051	0.043
42	0.175	0.140	0.117	0.100	0.088	0.058	0.053	0.044
43	0.180	0.144	0.120	0.103	0.090	0.060	0.054	0.045
44	0.184	0.147	0.122	0.105	0.092	0.061	0.055	0.046
45	0.188	0.150	0.125	0.107	0.094	0.063	0.056	0.047
46	0.192	0.154	0.128	0.110	0.096	0.064	0.058	0.048
47	0.196	0.157	0.131	0.112	0.098	0.065	0.059	0.049

Design Considerations

When using adjustable duct sections, within the duct horizontally or vertically, the minimum overlap required between the adjustable duct and the standard duct depends on the duct diameter (**Table 6**). In some scenarios, adjustable duct pieces will need to be cut in the field.

TABLE 6 - MINIMUM OVERLAP	
Diameter	Min Overlap for Adjustable Duct
8"	4"
10"	5"
12"	6"
14"	6"
16"	6"
18"	6"
20"	6"
22"	6"
24"	6"

Alignment and Bracing of Grease Duct

Grease duct has the characteristics of a continuous stainless steel pipe and it will expand and contract along its entire length with changes in its temperature. For this reason, conventional methods of attaching guides and braces to the outer wall of the grease duct cannot be used. Correctly installed support rings, saddles, and wall guide assemblies will serve to keep the duct aligned, provide for adequate resistance to lateral loads, and allow the free axial expansion and contraction movement. A simplified rule for duct expansion is that the axial growth will be approximately 1 inch per 100 feet of pipe length for each 100 degrees Fahrenheit the exhaust vapor temperature is above the surrounding air temperature. For support spacing information, refer to the pages on the different support methods later in this document.

Duct Diameter Sizing

The velocity of the air moving through the grease rated duct work must comply with NFPA-96, IMC, and local standards. The RuppAir Duct Diameter Sizing Charts will help when designing duct runs. These are located in **Appendix A** of this guide and on our website under Resources > Duct Sizing Information.

DW Offset Assembly 1 Degree

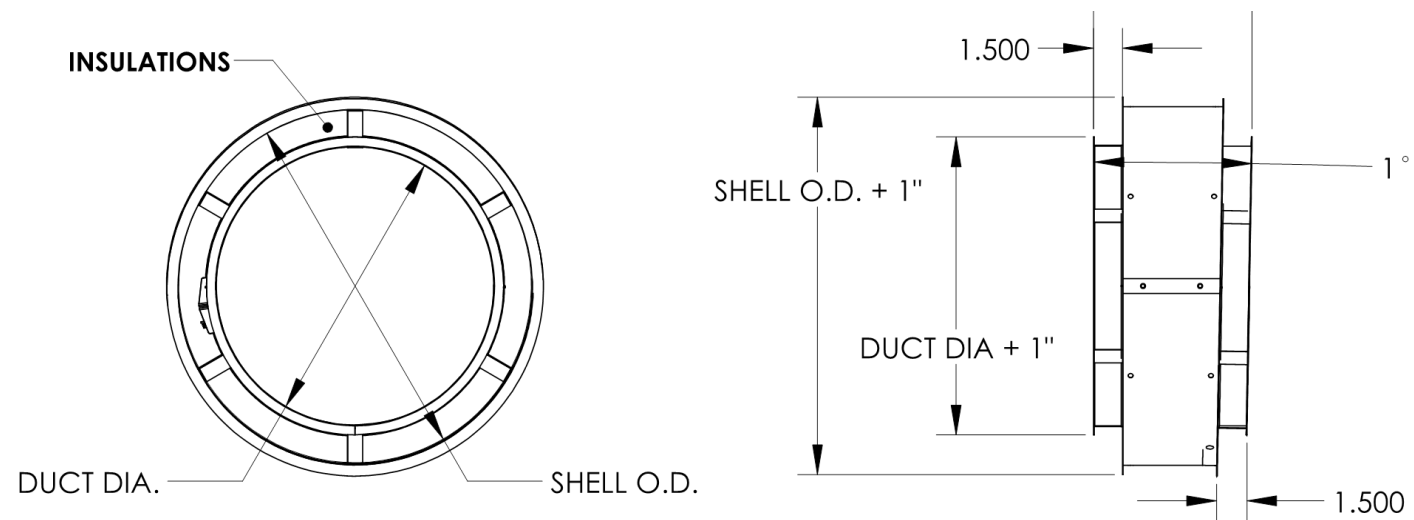
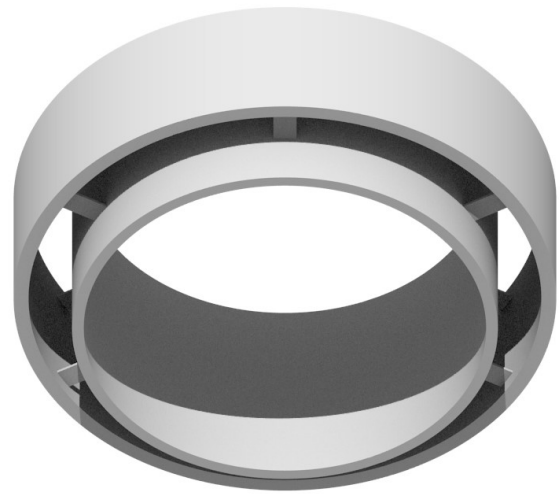

DW Offset Assembly 1 Degree

DUCT INFORMATION				
Duct Diameter	Layers	Part Number	2R = (Duct OD + 4) = Shell OD	3R, 3Z = (Duct OD + 6) = Shell OD
8"	2	DW0801DWOFFSETASY	12.000"	N/A
8"	3	DW0801DWOFFSETASY	N/A	14.000"
10"	2	DW1001DWOFFSETASY	14.000"	N/A
10"	3	DW1001DWOFFSETASY	N/A	16.000"
12"	2	DW1201DWOFFSETASY	16.000"	N/A
12"	3	DW1201DWOFFSETASY	N/A	18.000"
14"	2	DW1401DWOFFSETASY	18.000"	N/A
14"	3	DW1401DWOFFSETASY	N/A	20.000"
16"	2	DW1601DWOFFSETASY	20.000"	N/A
16"	3	DW1601DWOFFSETASY	N/A	22.000"
18"	3	DW1801DWOFFSETASY	N/A	24.000"
20"	3	DW2001DWOFFSETASY	N/A	26.000"
22"	3	DW2201DWOFFSETASY	N/A	28.000"
24"	3	DW2401DWOFFSETASY	N/A	30.000"

INSULATION LENGTHS PER NUMBER OF LAYERS / DIAMETERS				
Duct Diameter	2 Layers O.D.	2 Layer - Insulation Length	3 Layers O.D.	3 Layer - Insulation Length
8"	12"	72"	14"	116"
10"	14"	85"	16"	135"
12"	16"	97"	18"	154"
14"	18"	110"	20"	173"
16"	20"	122"	22"	191"
18"		N/A	24"	210"
20"		N/A	26"	229"
22"		N/A	28"	248"
24"		N/A	30"	267"

DW Offset Assembly 2 Degree

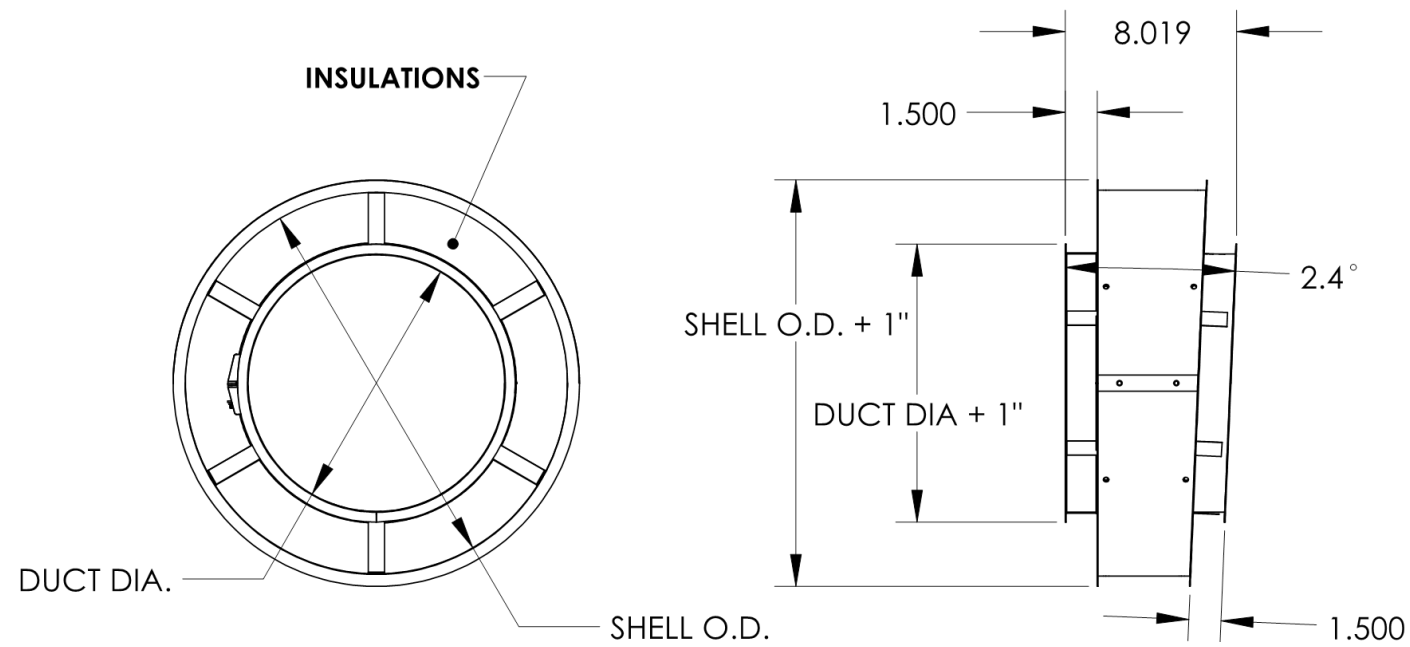
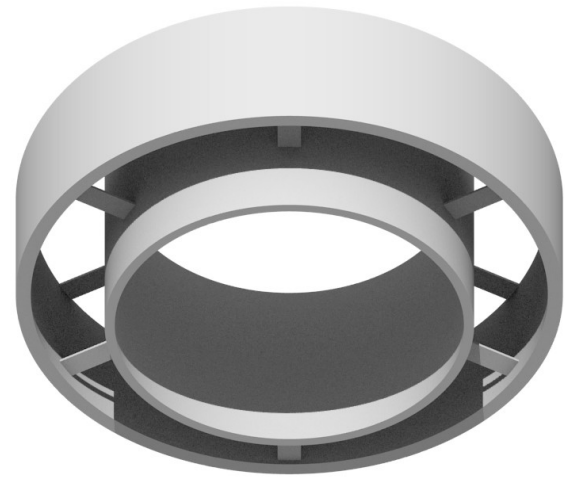

DW Offset Assembly 2 Degree

DUCT INFORMATION				
Duct Diameter	2 Layers O.D.	Part Number	2R = (Duct OD + 4) = Shell OD	3R, 3Z = (Duct OD + 6) = Shell OD
8"	2	DW0802DWOFFSETASY	12.000"	N/A
8"	3	DW0802DWOFFSETASY	N/A	14.000"
10"	2	DW1002DWOFFSETASY	14.000"	N/A
10"	3	DW1002DWOFFSETASY	N/A	16.000"
12"	2	DW1202DWOFFSETASY	16.000"	N/A
12"	3	DW1202DWOFFSETASY	N/A	18.000"
14"	2	DW1402DWOFFSETASY	18.000"	N/A
14"	3	DW1402DWOFFSETASY	N/A	20.000"
16"	2	DW1602DWOFFSETASY	20.000"	N/A
16"	3	DW1602DWOFFSETASY	N/A	22.000"
18"	3	DW1802DWOFFSETASY	N/A	24.000"
20"	3	DW2002DWOFFSETASY	N/A	26.000"
22"	3	DW2202DWOFFSETASY	N/A	28.000"
24"	3	DW2402DWOFFSETASY	N/A	30.000"

INSULATION LENGTHS PER NUMBER OF LAYERS / DIAMETERS				
Duct Diameter	2 Layers O.D.	2 Layer - Insulation Length	3 Layers O.D.	3 Layer - Insulation Length
8"	12"	72"	14"	116"
10"	14"	85"	16"	135"
12"	16"	97"	18"	154"
14"	18"	110"	20"	173"
16"	20"	122"	22"	191"
18"		N/A	24"	210"
20"		N/A	26"	229"
22"		N/A	28"	248"
24"		N/A	30"	267"

DW Angle 30 Degree

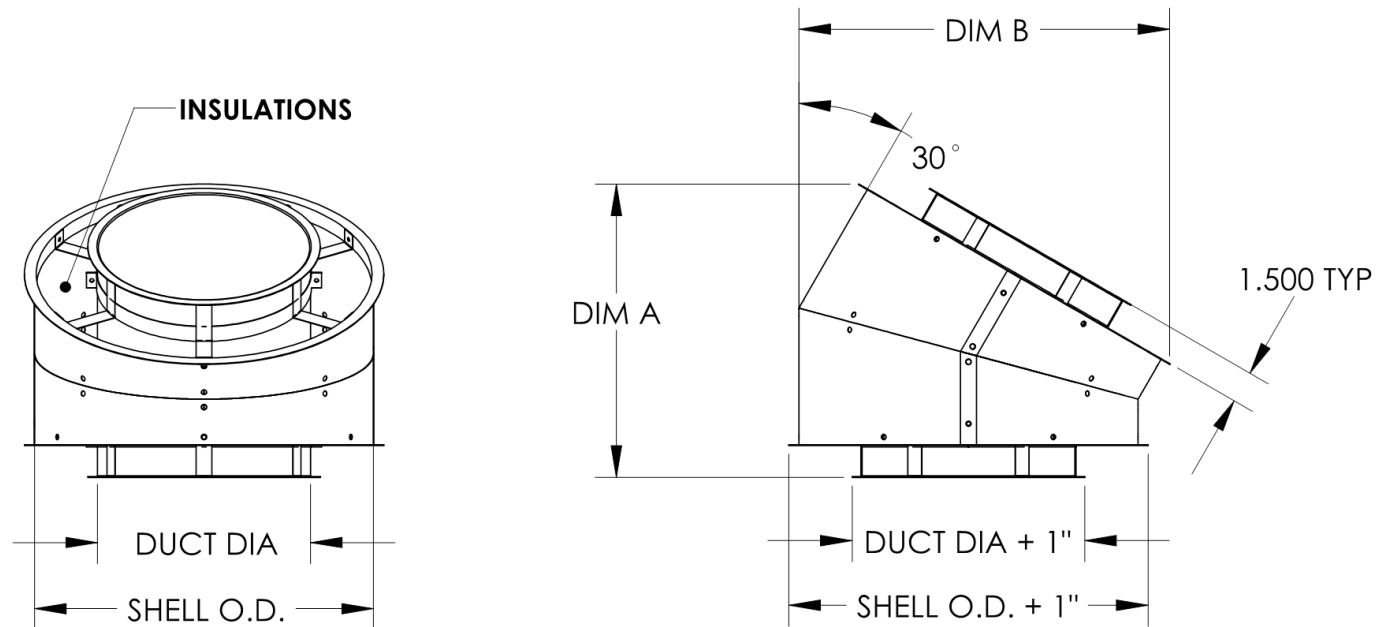

DW Angle 30 Degree

DUCT INFORMATION						
Duct Diameter	Layers	Dim A	Dim B	Part Number	2R = (Duct OD + 4) = Shell OD	3R, 3Z = (Duct OD + 6) = Shell OD
8"	2	12.366"	13.694"	DW0830DWASY	12.000"	N/A
8"	3	12.866"	15.560"	DW0830DWASY	N/A	14.000"
10"	2	13.366"	15.694"	DW1030DWASY	14.000"	N/A
10"	3	13.866"	17.560"	DW1030DWASY	N/A	16.000"
12"	2	14.366"	17.694"	DW1230DWASY	16.000"	N/A
12"	3	14.866"	19.560"	DW1230DWASY	N/A	18.000"
14"	2	15.366"	19.694"	DW1430DWASY	18.000"	N/A
14"	3	15.866"	21.560"	DW1430DWASY	N/A	20.000"
16"	2	16.366"	21.694"	DW1630DWASY	20.000"	N/A
16"	3	16.866"	23.560"	DW1630DWASY	N/A	22.000"
18"	3	17.866"	25.560"	DW1830DWASY	N/A	24.000"
20"	3	18.866"	27.560"	DW2030DWASY	N/A	26.000"
22"	3	19.866"	29.560"	DW2230DWASY	N/A	28.000"
24"	3	20.866"	31.560"	DW2430DWASY	N/A	30.000"

INSULATION LENGTHS PER NUMBER OF LAYERS / DIAMETERS				
Duct Diameter	2 Layers O.D.	2 Layer - Insulation Length	3 Layers O.D.	3 Layer - Insulation Length
8"	12"	72"	14"	116"
10"	14"	85"	16"	135"
12"	16"	97"	18"	154"
14"	18"	110"	20"	173"
16"	20"	122"	22"	191"
18"		N/A	24"	210"
20"		N/A	26"	229"
22"		N/A	28"	248"
24"		N/A	30"	267"

DW Angle 45 Degree

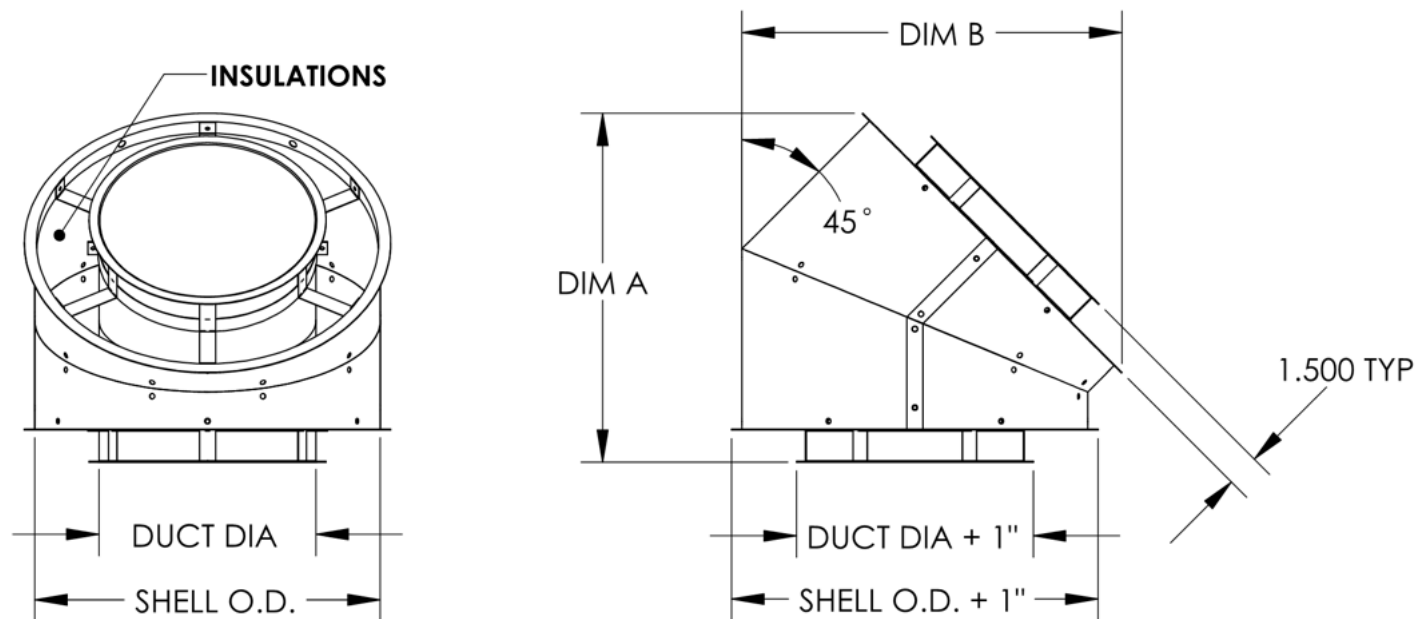

DW Angle 45 Degree

DUCT INFORMATION						
Duct Diameter	Layers	Dim A	Dim B	Part Number	2R = (Duct OD + 4) = Shell OD	3R, 3Z = (Duct OD + 6) = Shell OD
8"	2	14.072"	13.952"	DW0845DWASY	12.000"	N/A
8"	3	14.779"	15.631"	DW0845DWASY	N/A	14.000"
10"	2	15.486"	15.924"	DW1045DWASY	14.000"	N/A
10"	3	16.193"	17.631"	DW1045DWASY	N/A	16.000"
12"	2	16.900"	17.924"	DW1245DWASY	16.000"	N/A
12"	3	17.607"	19.631"	DW1245DWASY	N/A	18.000"
14"	2	18.314"	19.924"	DW1445DWASY	18.000"	N/A
14"	3	19.022"	21.631"	DW1445DWASY	N/A	20.000"
16"	2	19.728"	21.924"	DW1645DWASY	20.000"	N/A
16"	3	20.435"	23.631"	DW1645DWASY	N/A	22.000"
18"	3	21.850"	25.631"	DW1845DWASY	N/A	24.000"
20"	3	23.264"	27.631"	DW2045DWASY	N/A	26.000"
22"	3	24.678"	29.631"	DW2245DWASY	N/A	28.000"
24"	3	26.092"	31.631"	DW2445DWASY	N/A	30.000"

INSULATION LENGTHS PER NUMBER OF LAYERS / DIAMETERS				
Duct Diameter	2 Layers O.D.	2 Layer - Insulation Length	3 Layers O.D.	3 Layer - Insulation Length
8"	12"	72"	14"	116"
10"	14"	85"	16"	135"
12"	16"	97"	18"	154"
14"	18"	110"	20"	173"
16"	20"	122"	22"	191"
18"		N/A	24"	210"
20"		N/A	26"	229"
22"		N/A	28"	248"
24"		N/A	30"	267"

DW Angle 90 Degree

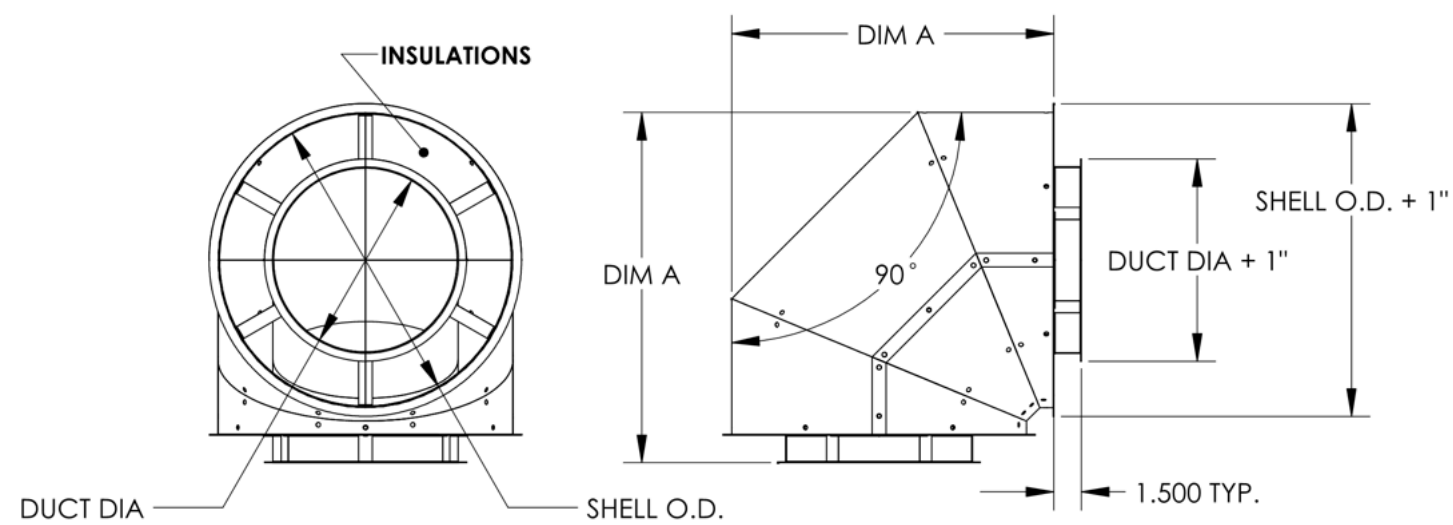

DW Angle 90 Degree

DUCT INFORMATION					
Duct Diameter	Layers	Dim A	Part Number	2R = (Duct OD + 4) = Shell OD	3R, 3Z (Duct OD + 6) = Shell OD
8"	2	16.035"	DW0890DWASY	12.000"	N/A
8"	3	17.035"	DW0890DWASY	N/A	14.000"
10"	2	18.035"	DW1090DWASY	14.000"	N/A
10"	3	19.035"	DW1090DWASY	N/A	16.000"
12"	2	20.035"	DW1290DWASY	16.000"	N/A
12"	3	21.035"	DW1290DWASY	N/A	18.000"
14"	2	22.035"	DW1490DWASY	18.000"	N/A
14"	3	23.035"	DW1490DWASY	N/A	20.000"
16"	2	24.035"	DW1690DWASY	20.000"	N/A
16"	3	25.035"	DW1690DWASY	N/A	22.000"
18"	3	27.035"	DW1890DWASY	N/A	24.000"
20"	3	29.035"	DW2090DWASY	N/A	26.000"
22"	3	31.035"	DW2290DWASY	N/A	28.000"
24"	3	33.035"	DW2490DWASY	N/A	30.000"

INSULATION LENGTHS PER NUMBER OF LAYERS / DIAMETERS				
Duct Diameter	2 Layers O.D.	2 Layer - Insulation Length	3 Layers O.D.	3 Layer - Insulation Length
8"	12"	72"	14"	116"
10"	14"	85"	16"	135"
12"	16"	97"	18"	154"
14"	18"	110"	20"	173"
16"	20"	122"	22"	191"
18"		N/A	24"	210"
20"		N/A	26"	229"
22"		N/A	28"	248"
24"		N/A	30"	267"

DW Access Door Assembly

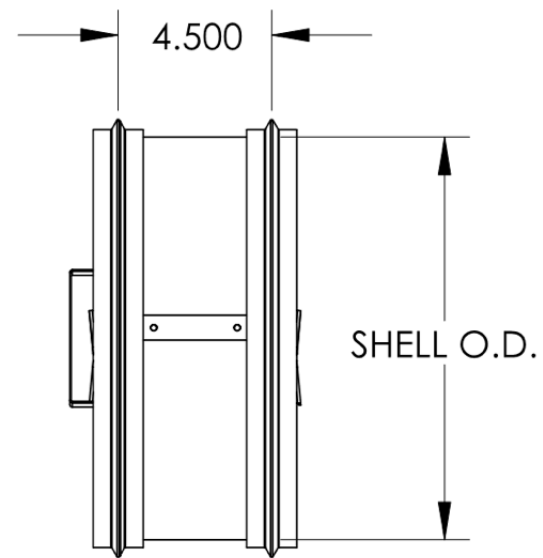
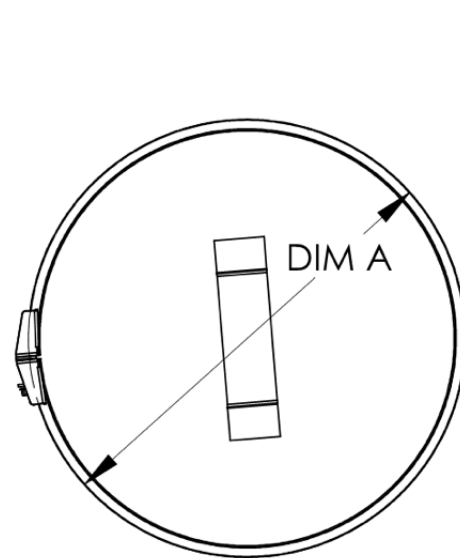

DW Access Door Assembly

DUCT INFORMATION							
Shell Diameter	Shell OD	Diameter A	Insulation Diameter	Part Number	10 PCF	10 PCF	8 PFC
12"	12.000"	13.000"	12.000"	DW12DWACCCOV	R2	Z3	R3
14"	14.000"	15.000"	14.000"	DW14DWACCCOV	R2	Z3	R3
16"	16.000"	17.000"	16.000"	DW16DWACCCOV	R2	Z3	R3
18"	18.000"	19.000"	18.000"	DW18DWACCCOV	R2	Z3	R3
20"	20.000"	21.000"	20.000"	DW20DWACCCOV	R2	Z3	R3
22"	22.000"	23.000"	22.000"	DW22DWACCCOV	N/A	Z3	R3
24"	24.000"	25.000"	24.000"	DW24DWACCCOV	N/A	Z3	R3
26"	26.000"	27.000"	26.000"	DW26DWACCCOV	N/A	Z3	R3
28"	28.000"	29.000"	28.000"	DW28DWACCCOV	N/A	Z3	R3
30"	30.000"	31.000"	30.000"	DW30DWACCCOV	N/A	Z3	R3

INSULATION LENGTHS PER NUMBER OF LAYERS / DIAMETERS						
Part Number	10 PCF	10 PCF	8 PCF	Duct Diameter	R2 - Shell Diameter	3R, 3Z - Shell Diameter
DW08DWTEAD	R2	Z3	R3	8.00"	12.00"	14.00"
DW10DWTEAD	R2	Z3	R3	10.00"	14.00"	16.00"
DW12DWTEAD	R2	Z3	R3	12.00"	16.00"	18.00"
DW14DWTEAD	R2	Z3	R3	14.00"	18.00"	20.00"
DW16DWTEAD	R2	Z3	R3	16.00"	20.00"	22.00"
DW18DWTEAD	N/A	Z3	R3	18.00"	N/A	24.00"
DW20DWTEAD	N/A	Z3	R3	20.00"	N/A	26.00"
DW22DWTEAD	N/A	Z3	R3	22.00"	N/A	28.00"
DW24DWTEAD	N/A	Z3	R3	24.00"	N/A	30.00"

DW Clamp Assembly

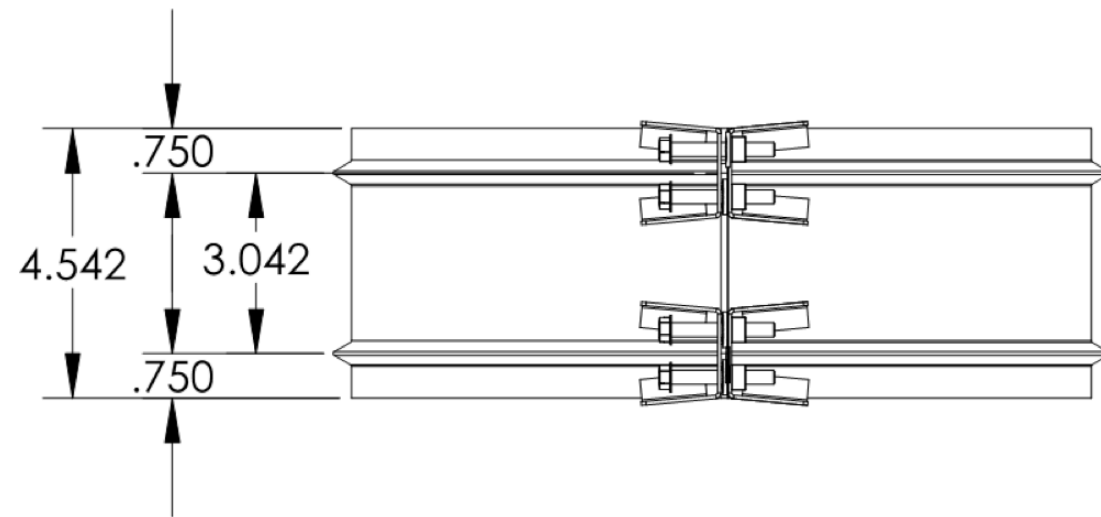

DW Clamp Assembly

PART INFORMATION							
Duct Diameter	Radius 1	Radius 2	JB Shear Length	Part Number	Part Number - 2R	Part Number - 3R	Part Number - 3Z
12"	6.22"	6.53"	39.265"	DW12DWCLASY	DW08DWCLASY-2R	N/A	N/A
14"	7.22"	7.53"	45.513"	DW14DWCLASY	DW10DWCLASY-2R	DW08DWCLASY-3R	DW08DWCLASY-3Z
16"	8.22"	8.53"	51.761"	DW16DWCLASY	DW12DWCLASY-2R	DW10DWCLASY-3R	DW10DWCLASY-3Z
18"	9.22"	9.53"	58.009"	DW18DWCLASY	DW14DWCLASY-2R	DW12DWCLASY-3R	DW12DWCLASY-3Z
20"	10.22"	10.53"	64.258"	DW20DWCLASY	DW16DWCLASY-2R	DW14DWCLASY-3R	DW14DWCLASY-3Z
22"	11.22"	11.53"	70.006"	DW22DWCLASY	N/A	DW16DWCLASY-3R	DW16DWCLASY-3Z
24"	12.22"	12.53"	76.259"	DW24DWCLASY	N/A	DW18DWCLASY-3R	DW18DWCLASY-3Z
26"	13.22"	13.53"	82.502"	DW26DWCLASY	N/A	DW20DWCLASY-3R	DW20DWCLASY-3Z
28"	14.22"	14.53"	88.875"	DW28DWCLASY	N/A	DW22DWCLASY-3R	DW22DWCLASY-3Z
30"	15.22"	15.53"	94.999"	DW30DWCLASY	N/A	DW24DWCLASY-3R	DW24DWCLASY-3Z

DW Tee Assembly

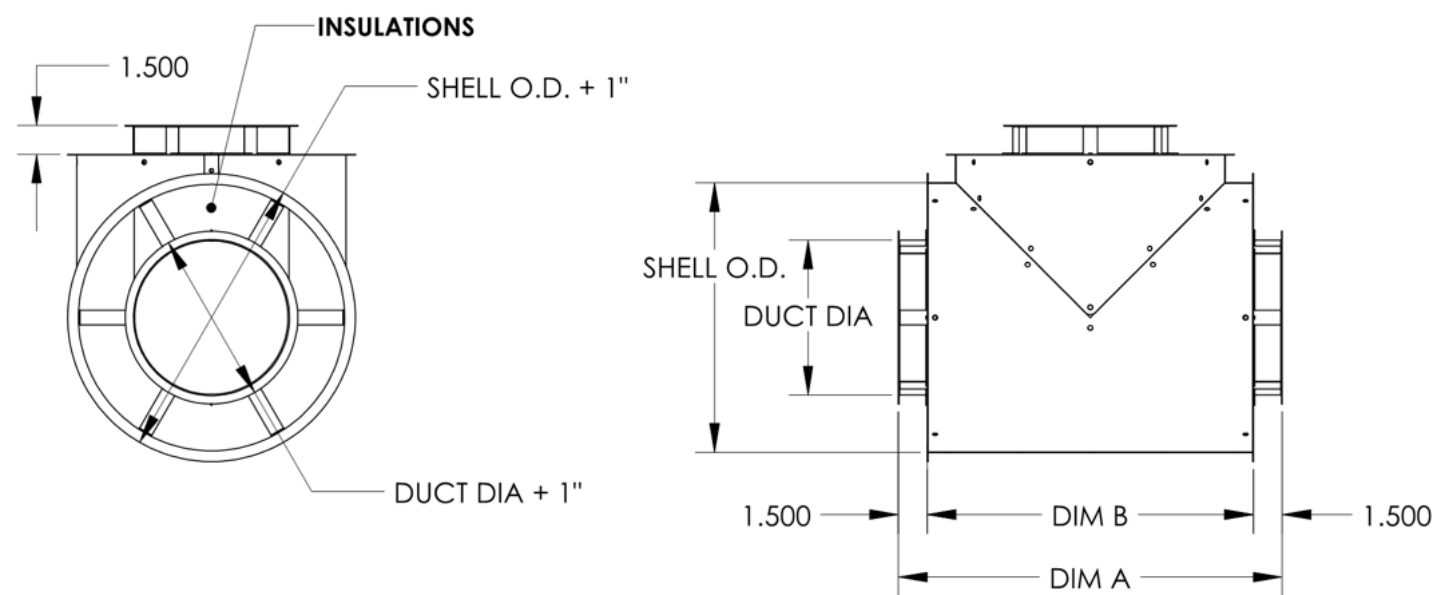
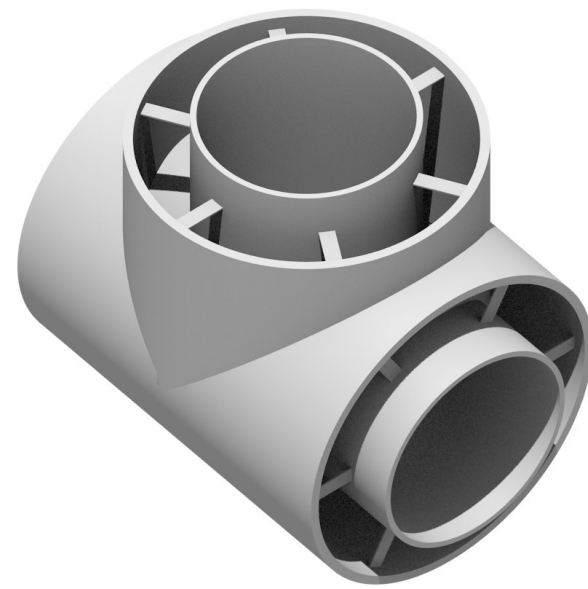

DW Tee Assembly

DUCT INFORMATION					
Duct Diameter	Dim A	Dim B	Part Number	2R = (Duct OD + 4) = Shell OD	3R, 3Z = (Duct OD + 6) = Shell OD
8"	20.012"	17.012"	DW08DWTEASY	12.000"	14.000"
10"	22.012"	19.012"	DW10DWTEASY	14.000"	16.000"
12"	24.012"	21.012"	DW12DWTEASY	16.000"	18.000"
14"	26.012"	23.012"	DW14DWTEASY	18.000"	20.000"
16"	28.012"	25.012"	DW16DWTEASY	20.000"	22.000"
18"	30.012"	27.012"	DW18DWTEASY	N/A	24.000"
20"	32.012"	29.012"	DW20DWTEASY	N/A	26.000"
22"	34.012"	31.012"	DW22DWTEASY	N/A	28.000"
24"	36.012"	33.012"	DW24DWTEASY	N/A	30.000"

INSULATION LENGTHS PER NUMBER OF LAYERS / DIAMETERS				
Duct Diameter	2 Layers O.D.	2 Layer - Insulation Length	3 Layers O.D.	3 Layer - Insulation Length
8"	12"	72"	14"	116"
10"	14"	85"	16"	135"
12"	16"	97"	18"	154"
14"	18"	110"	20"	173"
16"	20"	122"	22"	191"
18"		N/A	24"	210"
20"		N/A	26"	229"
22"		N/A	28"	248"
24"		N/A	30"	267"

DW Y Assembly

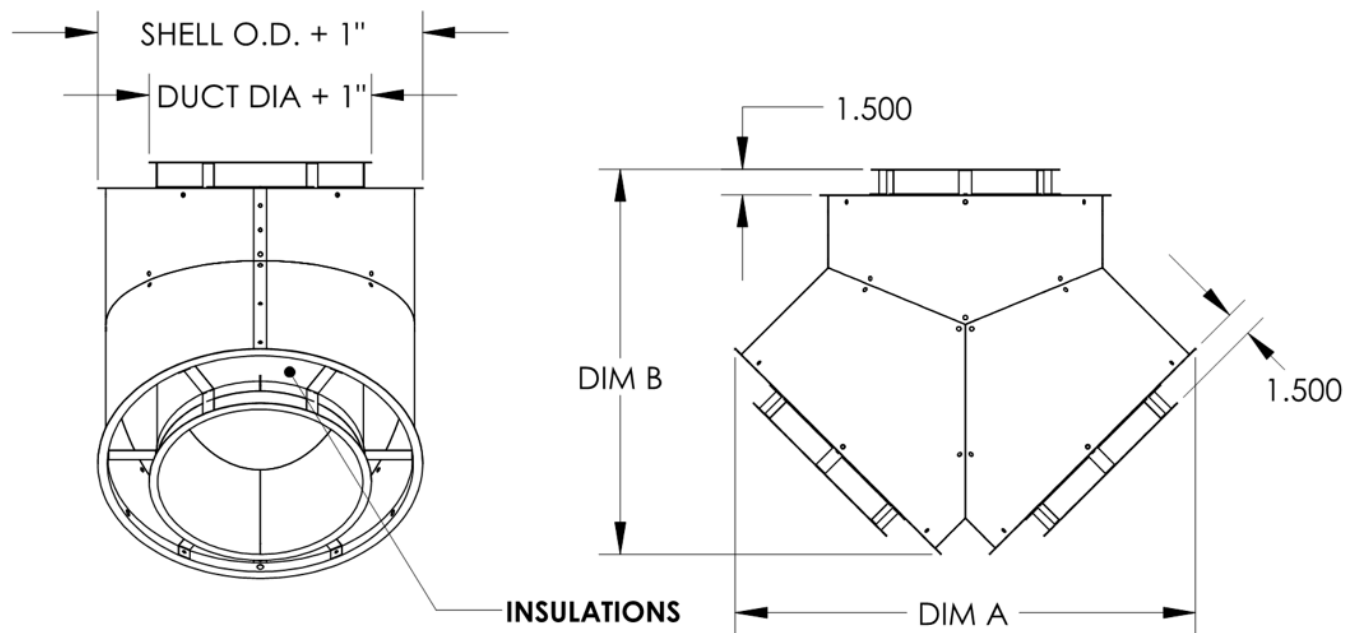
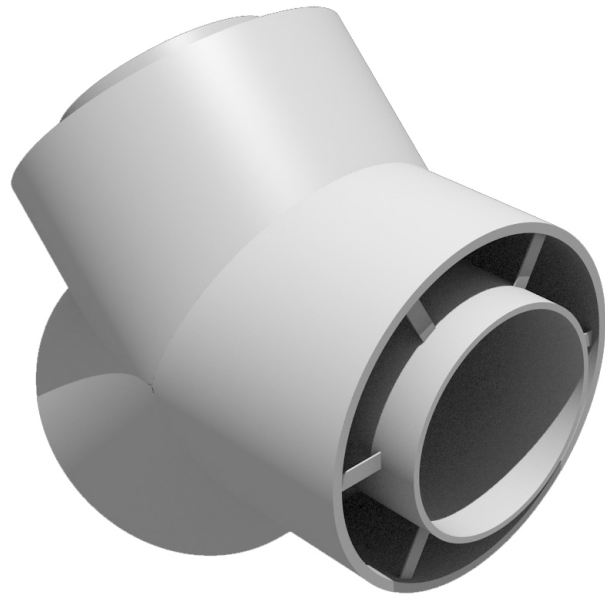

DW Y Assembly

DUCT INFORMATION						
Duct Diameter	Layers	Dim A	Dim B	Part Number	2R = (Duct OD + 4) = Shell OD	3R, 3Z = (Duct OD + 6) = Shell OD
8"	2	22.679"	20.011"	DW08DWYTEASY	12.000"	N/A
8"	3	24.093"	20.718"	DW08DWYTEASY	N/A	14.000"
10"	2	25.507"	21.840"	DW10DWYTEASY	14.000"	N/A
10"	3	26.921"	22.547"	DW10DWYTEASY	N/A	16.000"
12"	2	28.336"	23.668"	DW12DWYTEASY	16.000"	N/A
12"	3	29.750"	24.375"	DW12DWYTEASY	N/A	18.000"
14"	2	31.164"	25.496"	DW14DWYTEASY	18.000"	N/A
14"	3	32.578"	26.203"	DW14DWYTEASY	N/A	20.000"
16"	2	33.992"	27.325"	DW16DWYTEASY	20.000"	N/A
16"	3	35.407"	28.032"	DW16DWYTEASY	N/A	22.000"
18"	3	38.235"	29.861"	DW18DWYTEASY	N/A	24.000"
20"	3	41.063"	31.689"	DW20DWYTEASY	N/A	26.000"
22"	3	43.891"	33.517"	DW22DWYTEASY	N/A	28.000"
24"	3	46.720"	35.345"	DW24DWYTEASY	N/A	30.000"

INSULATION LENGTHS PER NUMBER OF LAYERS / DIAMETERS				
Duct Diameter	2 Layers O.D.	2 Layer - Insulation Length	3 Layers O.D.	3 Layer - Insulation Length
8"	12"	72"	14"	116"
10"	14"	85"	16"	135"
12"	16"	97"	18"	154"
14"	18"	110"	20"	173"
16"	20"	122"	22"	191"
18"		N/A	24"	210"
20"		N/A	26"	229"
22"		N/A	28"	248"
24"		N/A	30"	267"

DW Adjustable Assembly

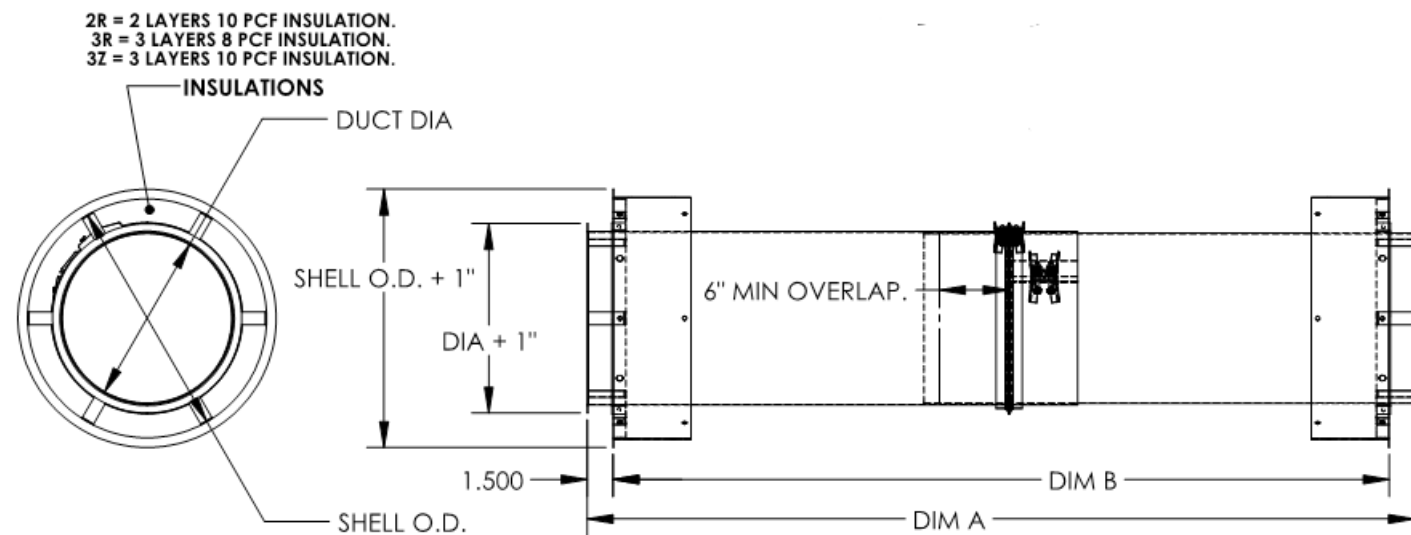
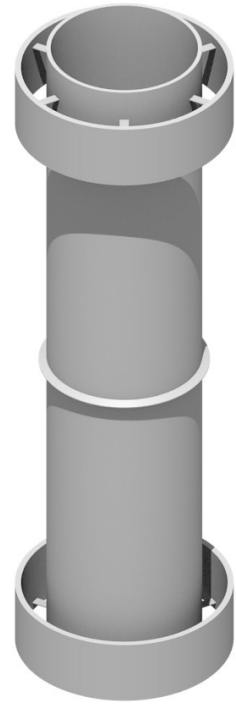

DW Adjustable Assembly

ADJUSTABLE PIECE RANGES

Adjustable Length (in part number)	Minimum Length	Maximum Length
27"	15"	27"
47"	30"	47"

DUCT INFORMATION

Duct Diameter	Part Number	2R = (Duct OD + 4) = Shell OD	3R, 3Z = (Duct OD + 6) = Shell OD	Dim A	Dim B
8"	DW0847DWAJD	12.000"	14.000"	47.00"	44.00"
10"	DW1047DWAJD	14.000"	16.000"	47.00"	44.00"
12"	DW1247DWAJD	16.000"	18.000"	47.00"	44.00"
14"	DW1447DWAJD	18.000"	20.000"	47.00"	44.00"
16"	DW1647DWAJD	20.000"	22.000"	47.00"	44.00"
18"	DW1847DWAJD	N/A	24.000"	47.00"	44.00"
20"	DW2047DWAJD	N/A	26.000"	47.00"	44.00"
22"	DW2247DWAJD	N/A	28.000"	47.00"	44.00"
24"	DW2447DWAJD	N/A	30.000"	47.00"	44.00"
8"	DW0827DWAJD	12.000"	14.000"	25.00"	22.00"
10"	DW1027DWAJD	14.000"	16.000"	25.00"	22.00"
12"	DW1227DWAJD	16.000"	18.000"	25.00"	22.00"
14"	DW1427DWAJD	18.000"	20.000"	25.00"	22.00"
16"	DW1627DWAJD	20.000"	22.000"	25.00"	22.00"
18"	DW1827DWAJD	N/A	24.000"	25.00"	22.00"
20"	DW2027DWAJD	N/A	26.000"	25.00"	22.00"
22"	DW2227DWAJD	N/A	28.000"	25.00"	22.00"
24"	DW2427DWAJD	N/A	30.000"	25.00"	22.00"

INSULATION LENGTHS PER NUMBER OF LAYERS / DIAMETERS

Duct Diameter	2 Layers O.D.	2 Layer - Insulation Length	3 Layers O.D.	3 Layer - Insulation Length
8"	12"	72"	14"	116"
10"	14"	85"	16"	135"
12"	16"	97"	18"	154"
14"	18"	110"	20"	173"
16"	20"	122"	22"	191"
18"	N/A		24"	210"
20"	N/A		26"	229"
22"	N/A		28"	248"
24"	N/A		30"	267"

DW Adjustable Assembly (Used with TP)

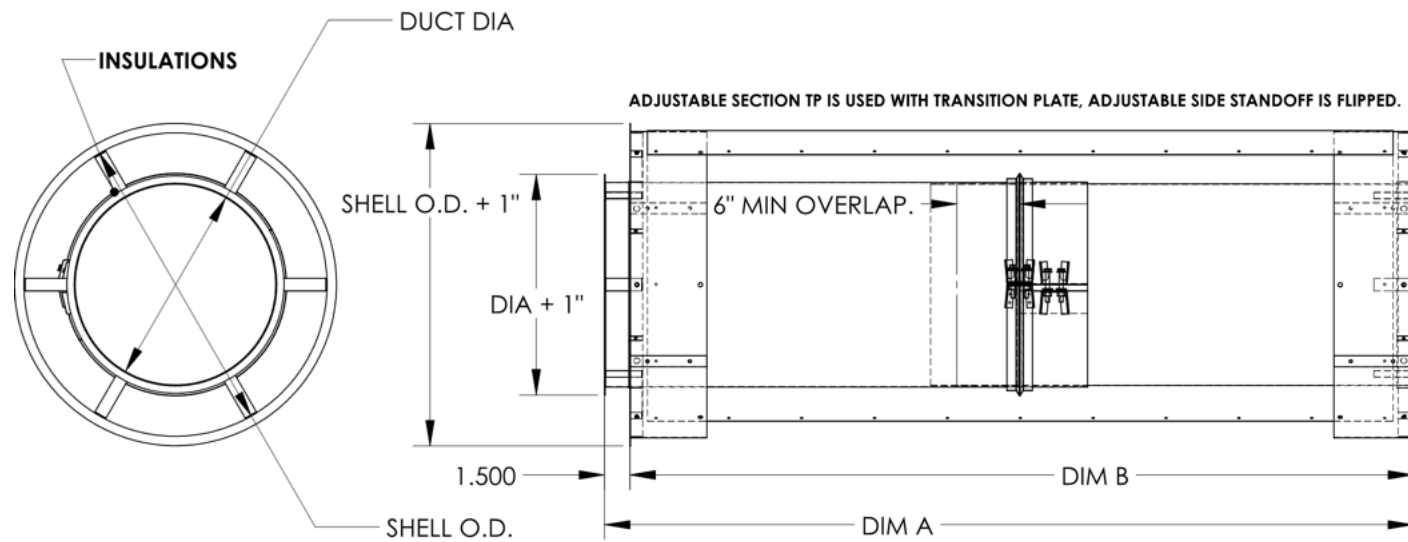
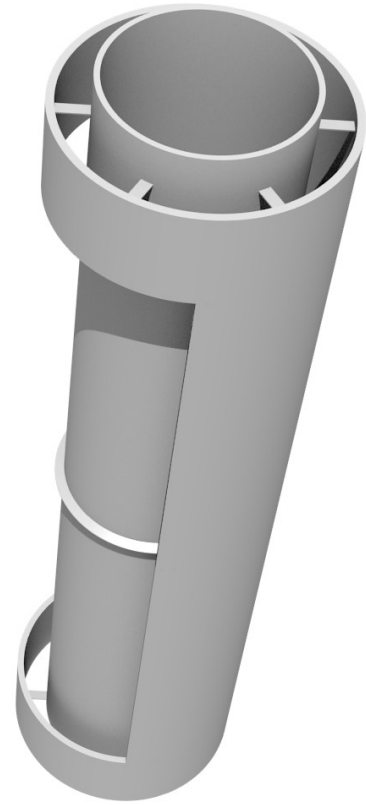

DW Adjustable Assembly (Used with TP)

DUCT INFORMATION					
Duct Diameter	Part Number	2R = (Duct OD + 4) = Shell OD	3R, 3Z = (Duct OD + 6) = Shell OD	Dim A	Dim B
8"	DW0847DWAJDTP	12.000"	14.000"	47.00"	45.50"
10"	DW1047DWAJDTP	14.000"	16.000"	47.00"	45.50"
12"	DW1247DWAJDTP	16.000"	18.000"	47.00"	45.50"
14"	DW1447DWAJDTP	18.000"	20.000"	47.00"	45.50"
16"	DW1647DWAJDTP	20.000"	22.000"	47.00"	45.50"
18"	DW1847DWAJDTP	N/A	24.000"	47.00"	45.50"
20"	DW2047DWAJDTP	N/A	26.000"	47.00"	45.50"
22"	DW2247DWAJDTP	N/A	26.000"	47.00"	45.50"
24"	DW2447DWAJDTP	N/A	30.000"	47.00"	45.50"
8"	DW0827DWAJDTP	12.000"	14.000"	25.00"	23.50"
10"	DW1027DWAJDTP	14.000"	16.000"	25.00"	23.50"
12"	DW1227DWAJDTP	16.000"	18.000"	25.00"	23.50"
14"	DW1427DWAJDTP	18.000"	20.000"	25.00"	23.50"
16"	DW1627DWAJDTP	20.000"	22.000"	25.00"	23.50"
18"	DW1827DWAJDTP	N/A	24.000"	25.00"	23.50"
20"	DW2027DWAJDTP	N/A	26.000"	25.00"	23.50"
22"	DW2227DWAJDTP	N/A	28.000"	25.00"	23.50"
24"	DW2427DWAJDTP	N/A	30.000"	25.00"	23.50"

INSULATION LENGTHS PER NUMBER OF LAYERS / DIAMETERS				
Duct Diameter	2 Layers O.D.	2 Layer - Insulation Length	3 Layers O.D.	3 Layer - Insulation Length
8"	12"	72"	14"	116"
10"	14"	85"	16"	135"
12"	16"	97"	18"	154"
14"	18"	110"	20"	173"
16"	20"	122"	22"	191"
18"		N/A	24"	210"
20"		N/A	26"	229"
22"		N/A	28"	248"
24"		N/A	30"	267"

DW End Cap Assembly

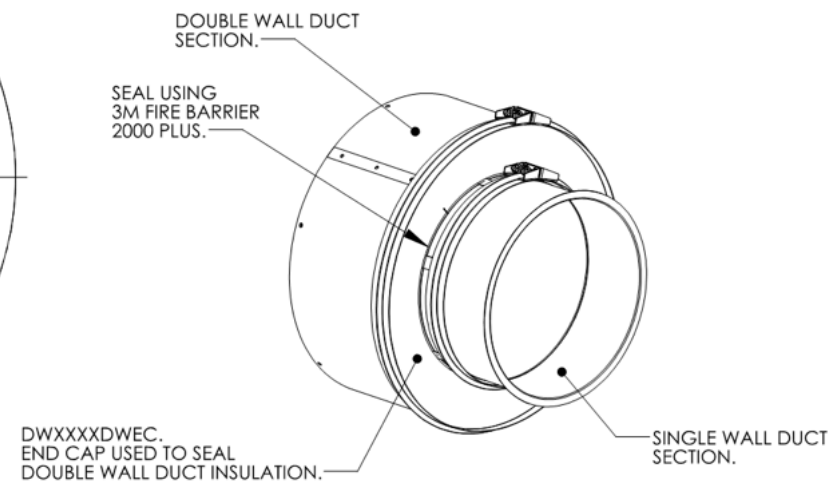
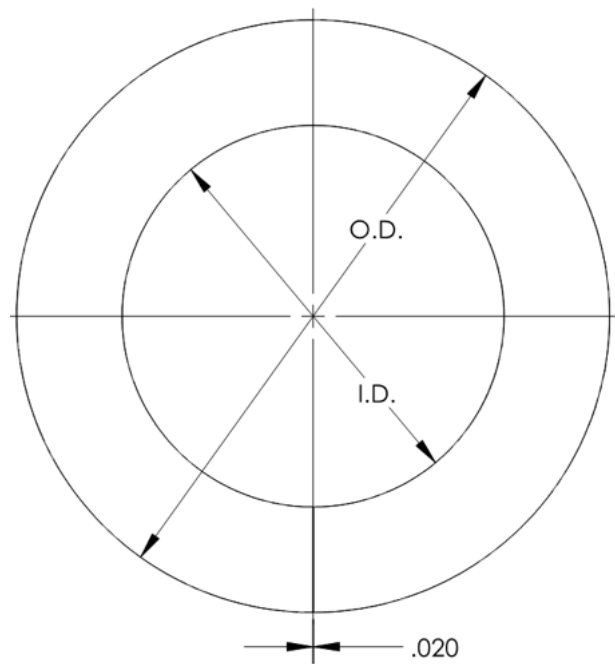

DW End Cap Assembly

DUCT INFORMATION					
Duct Diameter	Layers	I.D.	Part Number	2R - O.D.	3R, 3Z - O.D.
8"	2	8.375"	DW0812DWEC	13.000"	N/A
8"	3	8.375"	DW0814DWEC	N/A	15.000"
10"	2	10.375"	DW1014DWEC	15.000"	N/A
10"	3	10.375"	DW1016DWEC	N/A	17.000"
12"	2	12.375"	DW1216DWEC	17.000"	N/A
12"	3	12.375"	DW1218DWEC	N/A	19.000"
14"	2	14.375"	DW1418DWEC	19.000"	N/A
14"	3	14.375"	DW1420DWEC	N/A	21.000"
16"	2	16.375"	DW1620DWEC	21.000"	N/A
16"	3	16.375"	DW1622DWEC	N/A	23.000"
18"	3	18.375"	DW1824DWEC	N/A	25.000"
20"	3	20.375"	DW2026DWEC	N/A	27.000"
22"	3	22.375"	DW2228DWEC	N/A	29.000"
24"	3	24.375"	DW2430DWEC	N/A	31.000"

DW Straight Duct Assembly

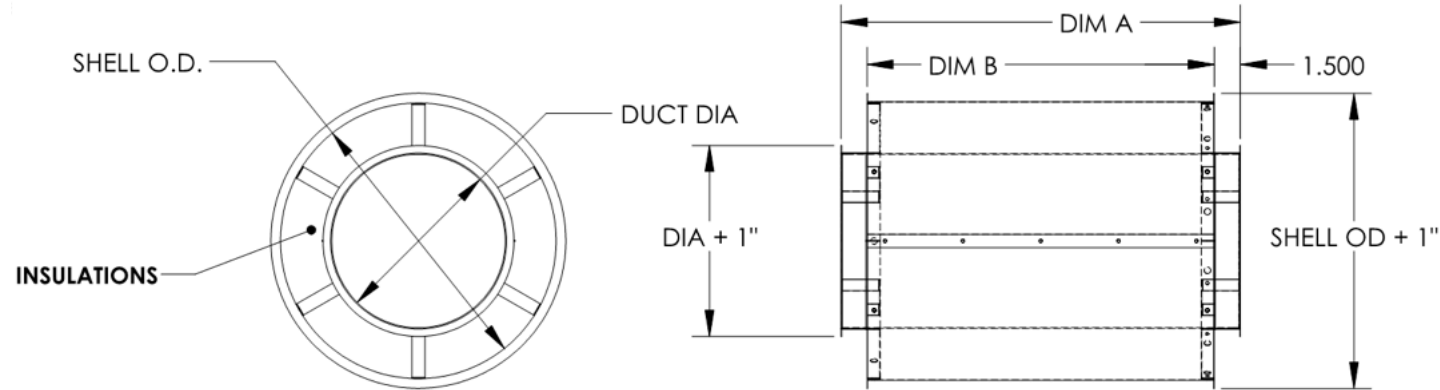
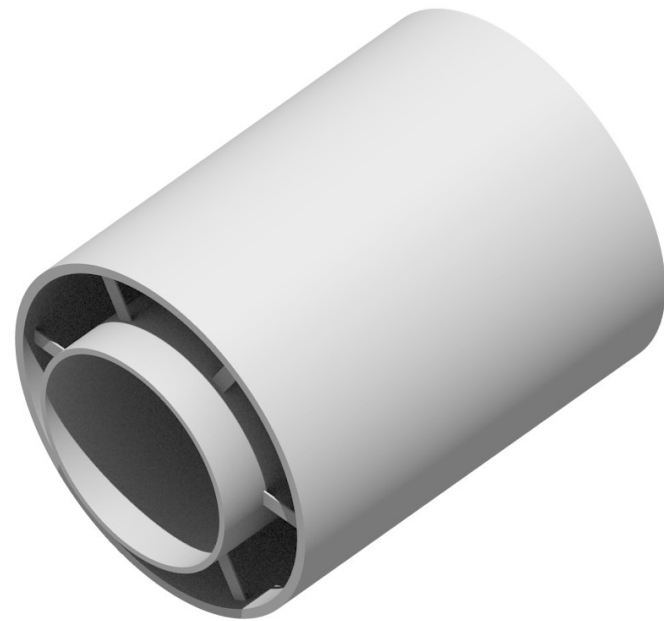

DW Straight Duct Assembly

DUCT INFORMATION					
Duct Diameter	Dim A	Dim B	Part Number	2R = (Duct OD + 4) = Shell OD	3R, 3Z = (Duct OD + 6) = Shell OD
8"	11.000"	8.000"	DW0811DWLT	12.000"	14.000"
8"	17.000"	14.000"	DW0817DWLT	12.000"	14.000"
8"	23.000"	20.000"	DW0823DWLT	12.000"	14.000"
8"	35.000"	32.000"	DW0835DWLT	12.000"	14.000"
8"	47.000"	44.000"	DW0847DWLT	12.000"	14.000"
10"	11.000"	8.000"	DW1011DWLT	14.000"	16.000"
10"	17.000"	14.000"	DW1017DWLT	14.000"	16.000"
10"	23.000"	20.000"	DW1023DWLT	14.000"	16.000"
10"	35.000"	32.000"	DW1035DWLT	14.000"	16.000"
10"	47.000"	44.000"	DW1047DWLT	14.000"	16.000"
12"	11.000"	8.000"	DW1211DWLT	16.000"	18.000"
12"	17.000"	14.000"	DW1217DWLT	16.000"	18.000"
12"	23.000"	20.000"	DW1223DWLT	16.000"	18.000"
12"	35.000"	32.000"	DW1235DWLT	16.000"	18.000"
12"	47.000"	44.000"	DW1247DWLT	16.000"	18.000"
14"	11.000"	8.000"	DW1411DWLT	18.000"	20.000"
14"	17.000"	14.000"	DW1417DWLT	18.000"	20.000"
14"	23.000"	20.000"	DW1423DWLT	18.000"	20.000"
14"	35.000"	32.000"	DW1435DWLT	18.000"	20.000"
14"	47.000"	44.000"	DW1447DWLT	18.000"	20.000"
16"	11.000"	8.000"	DW1611DWLT	20.000"	22.000"
16"	17.000"	14.000"	DW1617DWLT	20.000"	22.000"
16"	23.000"	20.000"	DW1623DWLT	20.000"	22.000"
16"	35.000"	32.000"	DW1635DWLT	20.000"	22.000"
16"	47.000"	44.000"	DW1647DWLT	20.000"	22.000"
18"	11.000"	8.000"	DW1811DWLT	N/A	24.000"
18"	17.000"	14.000"	DW1817DWLT	N/A	24.000"
18"	23.000"	20.000"	DW1823DWLT	N/A	24.000"
18"	35.000"	32.000"	DW1835DWLT	N/A	24.000"
18"	47.000"	44.000"	DW1847DWLT	N/A	24.000"
20"	11.000"	8.000"	DW2011DWLT	N/A	26.000"
20"	17.000"	14.000"	DW2017DWLT	N/A	26.000"
20"	23.000"	20.000"	DW2023DWLT	N/A	26.000"
20"	35.000"	32.000"	DW2035DWLT	N/A	26.000"
20"	47.000"	44.000"	DW2047DWLT	N/A	26.000"
22"	11.000"	8.000"	DW2211DWLT	N/A	28.000"
22"	17.000"	14.000"	DW2217DWLT	N/A	28.000"
22"	23.000"	20.000"	DW2223DWLT	N/A	28.000"
22"	35.000"	32.000"	DW2235DWLT	N/A	28.000"
22"	47.000"	44.000"	DW2247DWLT	N/A	28.000"
24"	11.000"	8.000"	DW2411DWLT	N/A	30.000"
24"	17.000"	14.000"	DW2417DWLT	N/A	30.000"
24"	23.000"	20.000"	DW2423DWLT	N/A	30.000"
24"	35.000"	32.000"	DW2435DWLT	N/A	30.000"
24"	47.000"	44.000"	DW2447DWLT	N/A	30.000"

DW Adapter Assembly

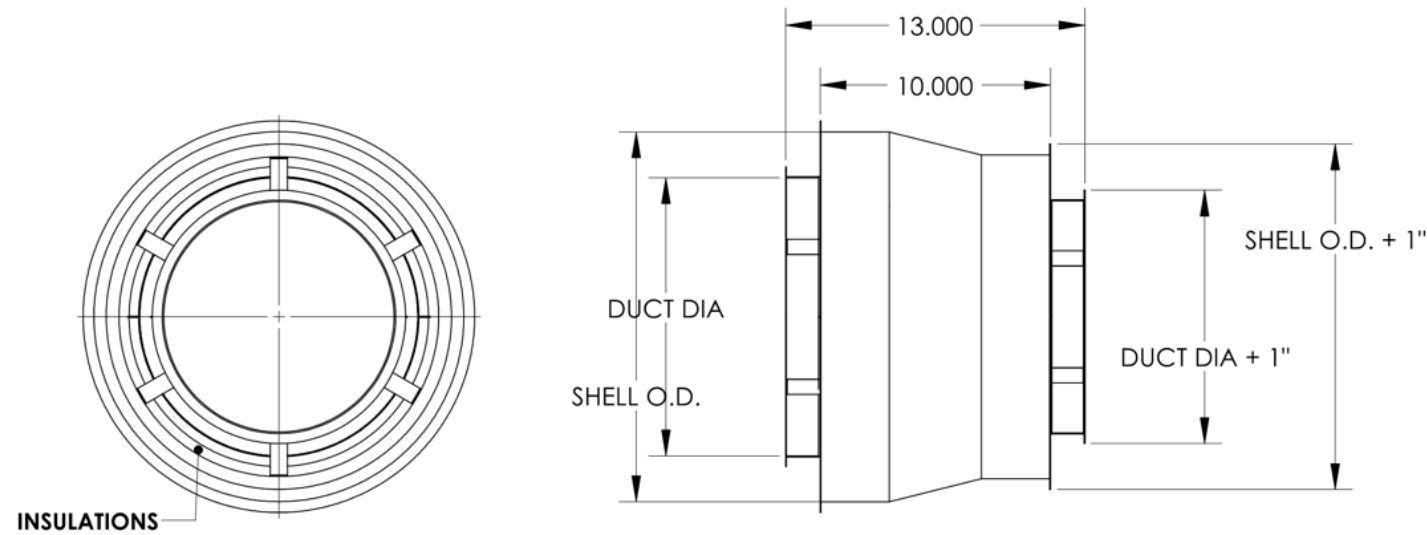
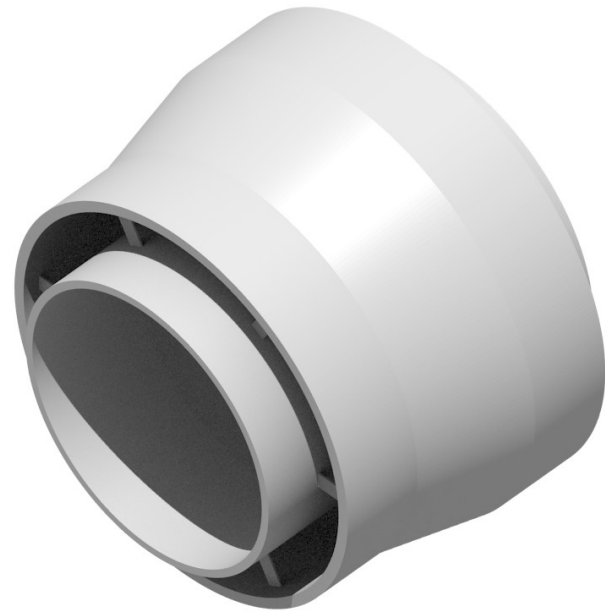

DW Adapter Assembly

DUCT INFORMATION				
Adapter Size Duct Diameter	Layers	Part Number	2R = (Duct OD + 4) = Shell OD	3R, 3Z = (Duct OD + 6) = Shell OD
8" to 12"	2	DW0812DWRNDADP2ASY	12" TO 16"	N/A
8" to 12"	3	DW0812DWRNDADP3ASY	N/A	14" TO 18"
10" to 12"	2	DW1012DWRNDADP2ASY	14" TO 16"	N/A
10" to 12"	3	DW1012DWRNDADP3ASY	N/A	16" TO 18"
10" to 14"	2	DW1014DWRNDADP2ASY	14" TO 18"	N/A
10" to 14"	3	DW1014DWRNDADP3ASY	N/A	16" TO 20"
12" to 14"	2	DW1214DWRNDADP2ASY	16" TO 18"	N/A
12" to 14"	3	DW1214DWRNDADP3ASY	N/A	18" TO 20"
12" to 16"	2	DW1216DWRNDADP2ASY	16" TO 20"	N/A
12" to 16"	3	DW1216DWRNDADP3ASY	N/A	18" TO 22"
12" to 18"	3	DW1218DWRNDADP3ASY	N/A	18" TO 24"
14" to 16"	3	DW1416DWRNDADP3ASY	N/A	20" TO 22"
14" to 18"	3	DW1418DWRNDADP3ASY	N/A	20" TO 24"
14" to 20"	3	DW1420DWRNDADP3ASY	N/A	20" TO 26"
16" to 20"	3	DW1620DWRNDADP3ASY	N/A	22" TO 26"
16" to 22"	3	DW1622DWRNDADP3ASY	N/A	22" TO 28"
16" to 24"	3	DW1624DWRNDADP3ASY	N/A	22" TO 30"
18" to 22"	3	DW1822DWRNDADP3ASY	N/A	24" TO 28"
18" to 24"	3	DW1824DWRNDADP3ASY	N/A	24" TO 30"
20" to 24"	3	DW2024DWRNDADP3ASY	N/A	26" TO 30"

INSULATION LENGTHS PER NUMBER OF LAYERS / DIAMETERS				
Duct Diameter	2 Layers O.D.	2 Layer - Insulation Length	3 Layers O.D.	3 Layer - Insulation Length
8"	12"	72"	14"	116"
10"	14"	85"	16"	135"
12"	16"	97"	18"	154"
14"	18"	110"	20"	173"
16"	20"	122"	22"	191"
18"		N/A	24"	210"
20"		N/A	26"	229"
22"		N/A	28"	248"
24"		N/A	30"	267"

DW Eccentric Adapter

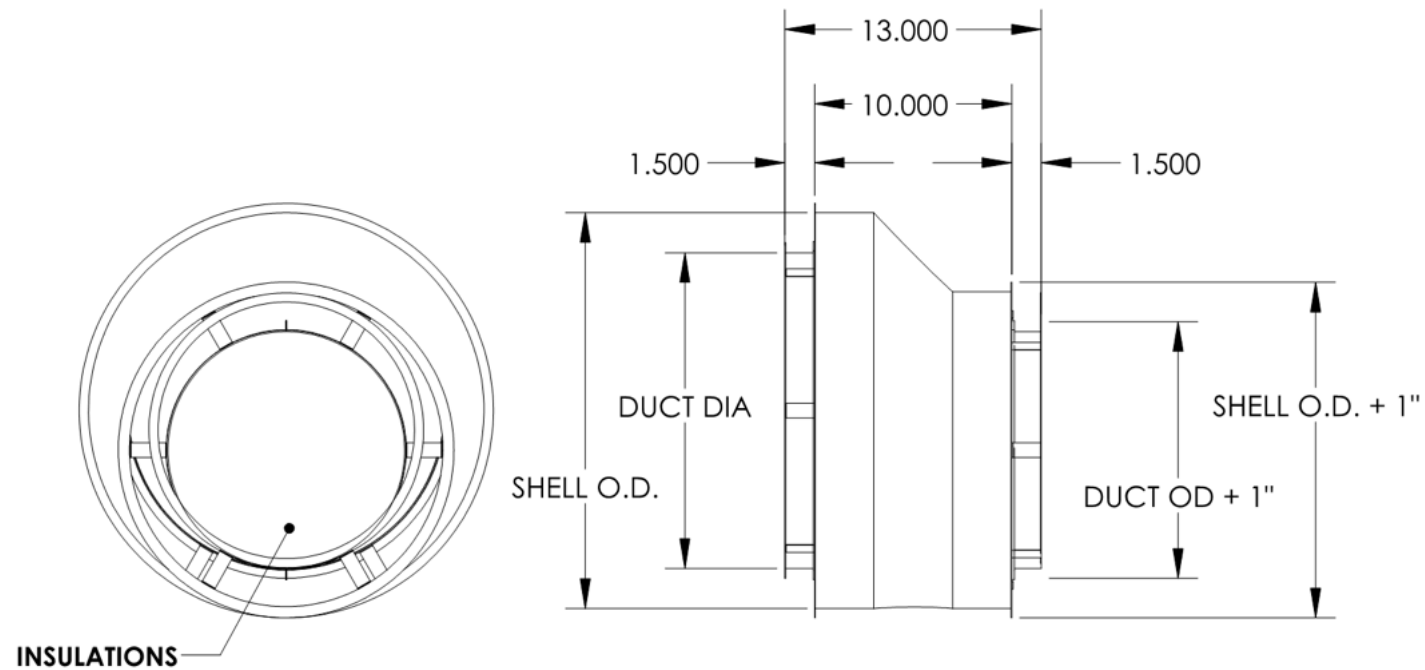
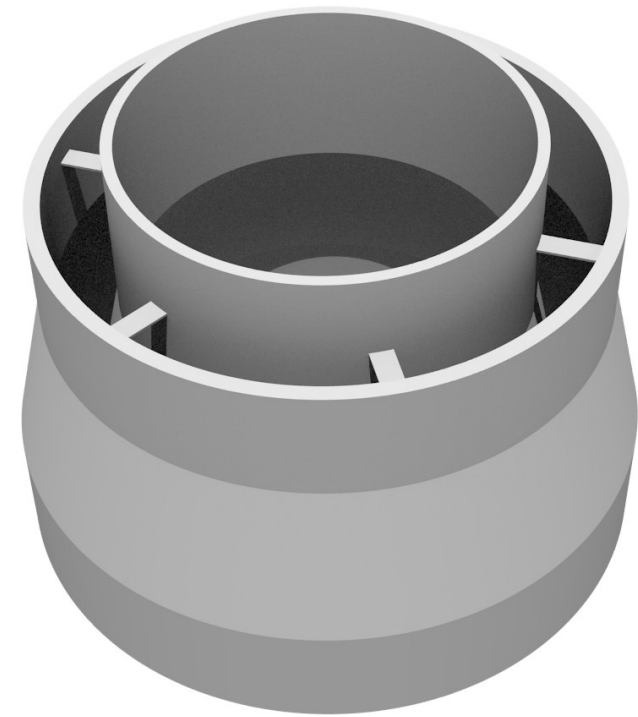

DW Eccentric Adapter

DUCT INFORMATION				
Adapter Size Duct Diameter	Layers	Part Number	2R = (Duct OD + 4) = Shell OD	3R, 3Z = (Duct OD + 6) = Shell OD
8" to 12"	2	DW0812DWRNDADPEC2ASY	12" TO 16"	N/A
8" to 12"	3	DW0812DWRNDADPEC3ASY	N/A	14" TO 18"
10" to 12"	2	DW1012DWRNDADPEC2ASY	14" TO 16"	N/A
10" to 12"	3	DW1012DWRNDADPEC3ASY	N/A	16" TO 18"
10" to 14"	2	DW1014DWRNDADPEC2ASY	14" TO 18"	N/A
10" to 14"	3	DW1014DWRNDADPEC3ASY	N/A	16" TO 20"
12" to 14"	2	DW1214DWRNDADPEC2ASY	16" TO 18"	N/A
12" to 14"	3	DW1214DWRNDADPEC3ASY	N/A	18" TO 20"
12" to 16"	2	DW1216DWRNDADPEC2ASY	16" TO 20"	N/A
12" to 16"	3	DW1216DWRNDADPEC3ASY	N/A	18" TO 22"
12" to 18"	3	DW1218DWRNDADPEC3ASY	N/A	18" TO 24"
14" to 16"	3	DW1416DWRNDADPEC3ASY	N/A	20" TO 22"
14" to 18"	3	DW1418DWRNDADPEC3ASY	N/A	20" TO 24"
14" to 20"	3	DW1420DWRNDADPEC3ASY	N/A	20" TO 26"
16" to 20"	3	DW1620DWRNDADPEC3ASY	N/A	22" TO 26"
16" to 22"	3	DW1622DWRNDADPEC3ASY	N/A	22" TO 28"
16" to 24"	3	DW1624DWRNDADPEC3ASY	N/A	22" TO 30"
18" to 22"	3	DW1822DWRNDADPEC3ASY	N/A	24" TO 28"
18" to 24"	3	DW1824DWRNDADPEC3ASY	N/A	24" TO 30"
20" to 24"	3	DW2024DWRNDADPEC3ASY	N/A	26" TO 30"

INSULATION LENGTHS PER NUMBER OF LAYERS / DIAMETERS				
Duct Diameter	2 Layers O.D.	2 Layer - Insulation Length	3 Layers O.D.	3 Layer - Insulation Length
8"	12"	72"	14"	116"
10"	14"	85"	16"	135"
12"	16"	97"	18"	154"
14"	18"	110"	20"	173"
16"	20"	122"	22"	191"
18"		N/A	24"	210"
20"		N/A	26"	229"
22"		N/A	28"	248"
24"		N/A	30"	267"

DW Square to Round Adapter

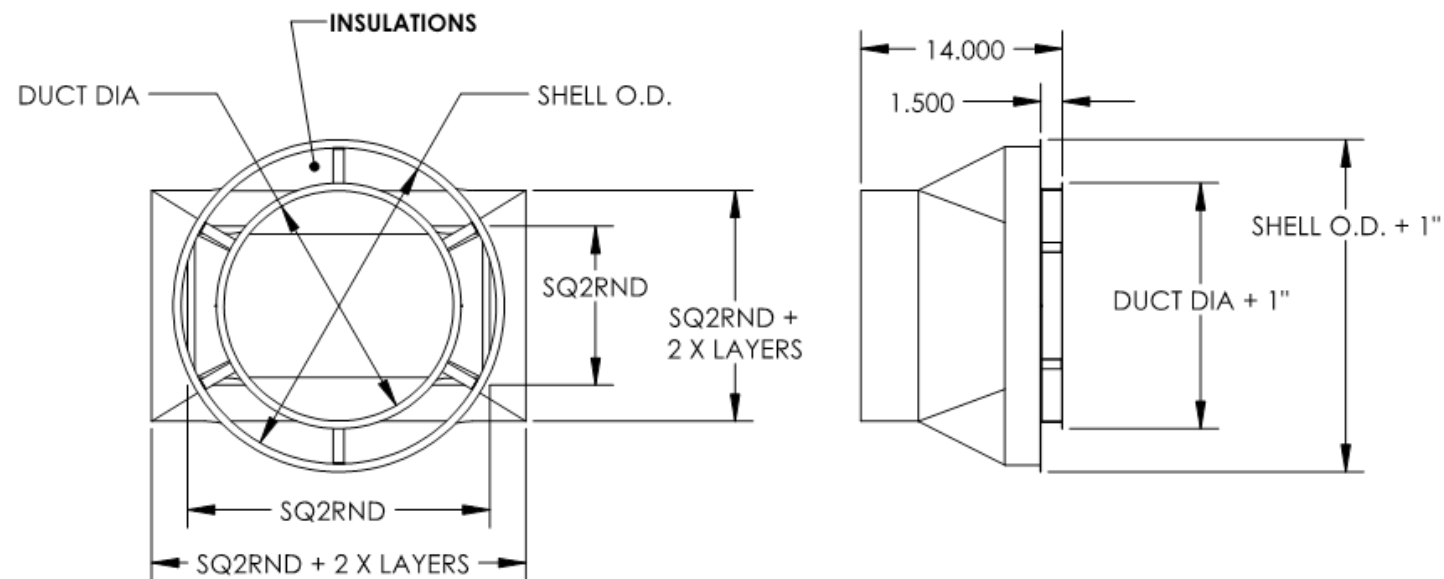
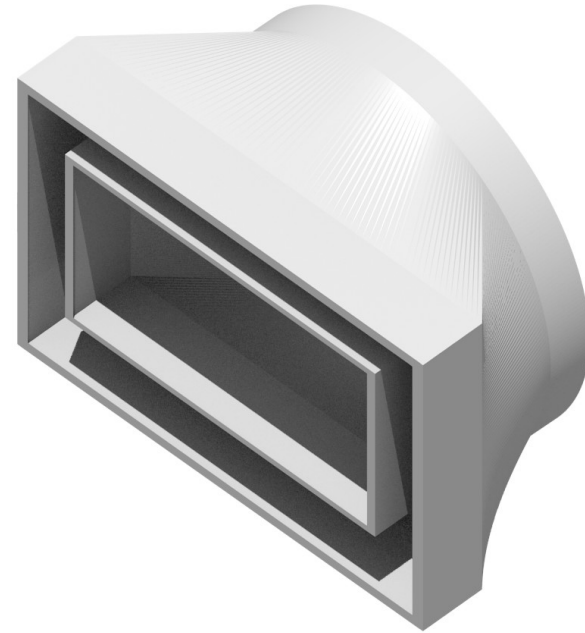

DW Square to Round Adapter

DUCT INFORMATION				
Adapter Size SQ2RND	Layers	Part Number	2R = (Duct OD + 4) = Shell Dims	3R, 3Z = (Duct OD + 6) = Shell Dims
6" X 9" to 8"	2	DW6X9TO8DWSQRNDADP2ASY	10" X 13" TO 12"	N/A
6" X 9" to 8"	3	DW6X9TO8DWSQRNDADP3ASY	N/A	12" X 15" TO 14"
6" X 13" to 10"	2	DW6X13TO10DWSQRNDADP2ASY	10" X 17" TO 14"	N/A
6" X 13" to 10"	3	DW6X13TO10DWSQRNDADP3ASY	N/A	12" X 19" TO 16"
10" X 12" to 12"	2	DW10X12TO12DWSQRNDADP2ASY	14" X 16" TO 16"	N/A
10" X 12" to 12"	3	DW10X12TO12DWSQRNDADP3ASY	N/A	16" X 18" TO 18"
10" X 16" to 14"	3	DW10X16TO14DWSQRNDADP3ASY	N/A	16" X 22" TO 20"
10" X 20" to 16"	3	DW10X20TO16DWSQRNDADP3ASY	N/A	16" X 26" TO 22"
10" X 26" to 18"	3	DW10X26TO18DWSQRNDADP3ASY	N/A	16" X 32" TO 24"
10" X 32" to 20"	3	DW10X32TO20DWSQRNDADP3ASY	N/A	16" X 38" TO 26"

INSULATION LENGTHS PER NUMBER OF LAYERS / DIAMETERS				
Duct Diameter	2 Layers O.D.	2 Layer - Insulation Length	3 Layers O.D.	3 Layer - Insulation Length
8"	12"	72"	14"	116"
10"	14"	85"	16"	135"
12"	16"	97"	18"	154"
14"	18"	110"	20"	173"
16"	20"	122"	22"	191"
18"		N/A	24"	210"
20"		N/A	26"	229"
22"		N/A	28"	248"
24"		N/A	30"	267"

Horizontal Duct Support

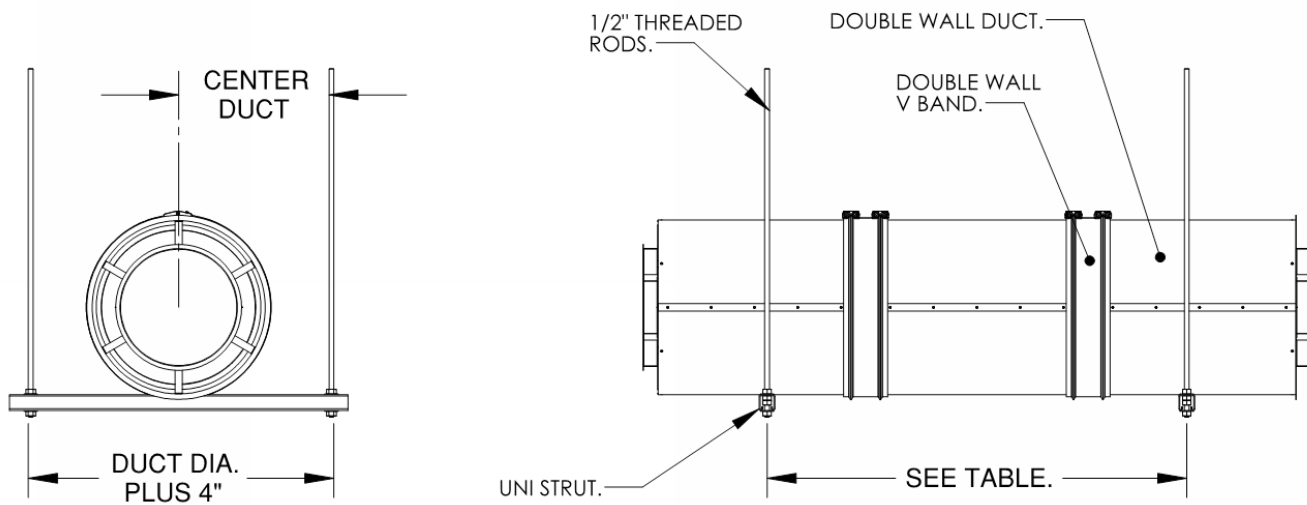
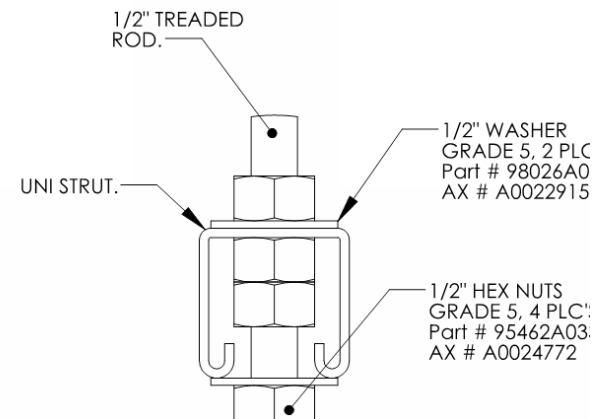
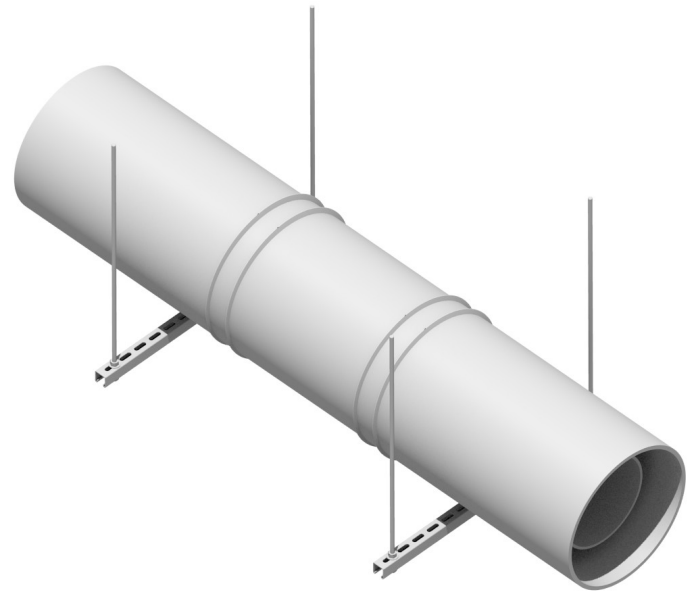

Horizontal Duct Support

HORIZONTAL SUPPORT SPACING	
DUCT DIAMETER	SUPPORT SPACING
8.00"	7'
10.00"	7'
12.00"	7'
14.00"	7'
16.00"	7'
18.00"	5'
20.00"	5'
22.00"	5'
24.00"	5'

INSULATION LENGTHS PER NUMBER OF LAYERS / DIAMETERS				
Duct Diameter	2 Layers O.D.	2 Layer - Insulation Length	3 Layers O.D.	3 Layer - Insulation Length
8"	12"	72"	14"	116"
10"	14"	85"	16"	135"
12"	16"	97"	18"	154"
14"	18"	110"	20"	173"
16"	20"	122"	22"	191"
18"	N/A		24"	210"
20"	N/A		26"	229"
22"	N/A		28"	248"
24"	N/A		30"	267"

Horizontal Duct Saddle Support

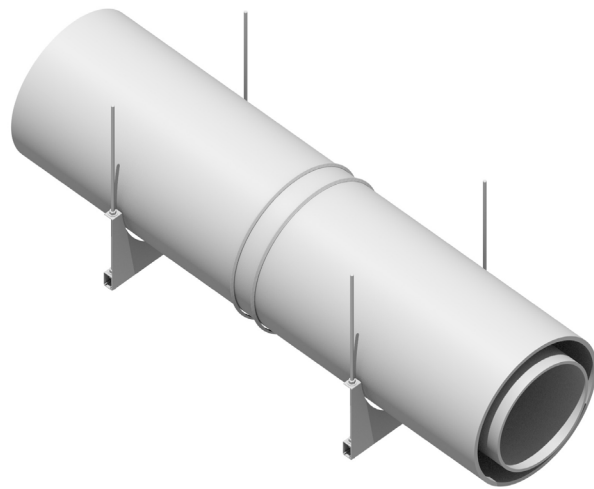

SADDLE BOTTOM.

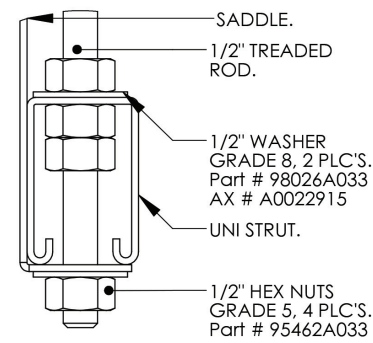

SADDLE TOP.

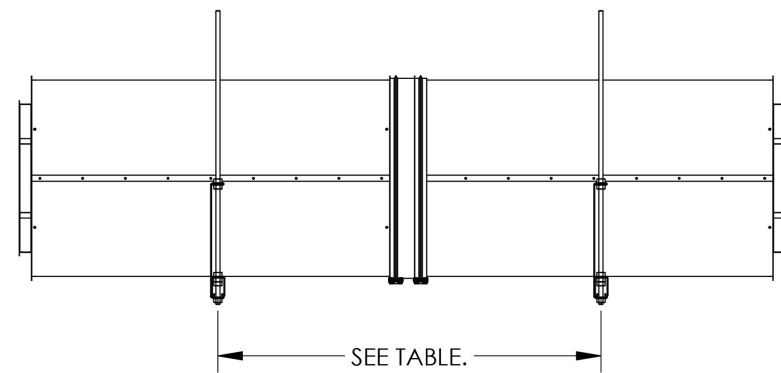
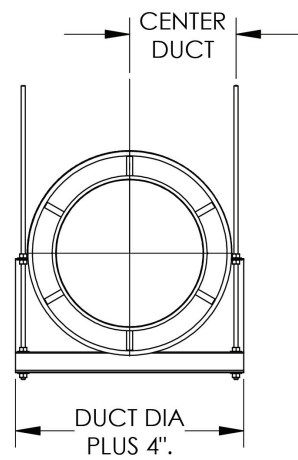
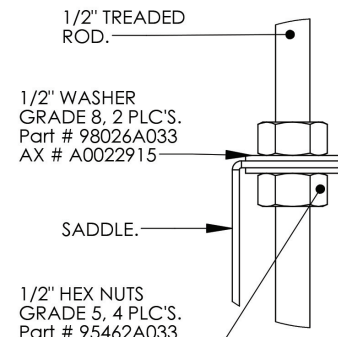

Horizontal Duct Saddle Support

HORIZONTAL SUPPORT SPACING	
DUCT DIAMETER	SUPPORT SPACING
8.00"	7'
10.00"	7'
12.00"	7'
14.00"	7'
16.00"	7'
18.00"	5'
20.00"	5'
22.00"	5'
24.00"	5'

INSULATION LENGTHS PER NUMBER OF LAYERS / DIAMETERS				
Duct Diameter	2 Layers O.D.	2 Layer - Insulation Length	3 Layers O.D.	3 Layer - Insulation Length
8"	12"	72"	14"	116"
10"	14"	85"	16"	135"
12"	16"	97"	18"	154"
14"	18"	110"	20"	173"
16"	20"	122"	22"	191"
18"	N/A		24"	210"
20"	N/A		26"	229"
22"	N/A		28"	248"
24"	N/A		30"	267"

Vertical Duct Floor Support

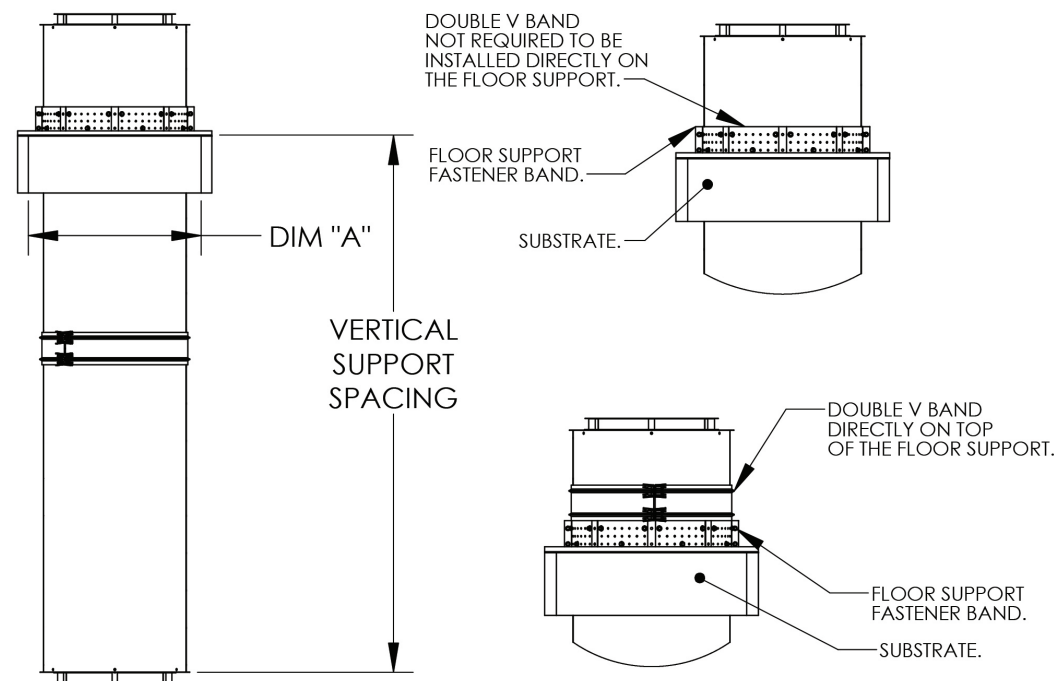
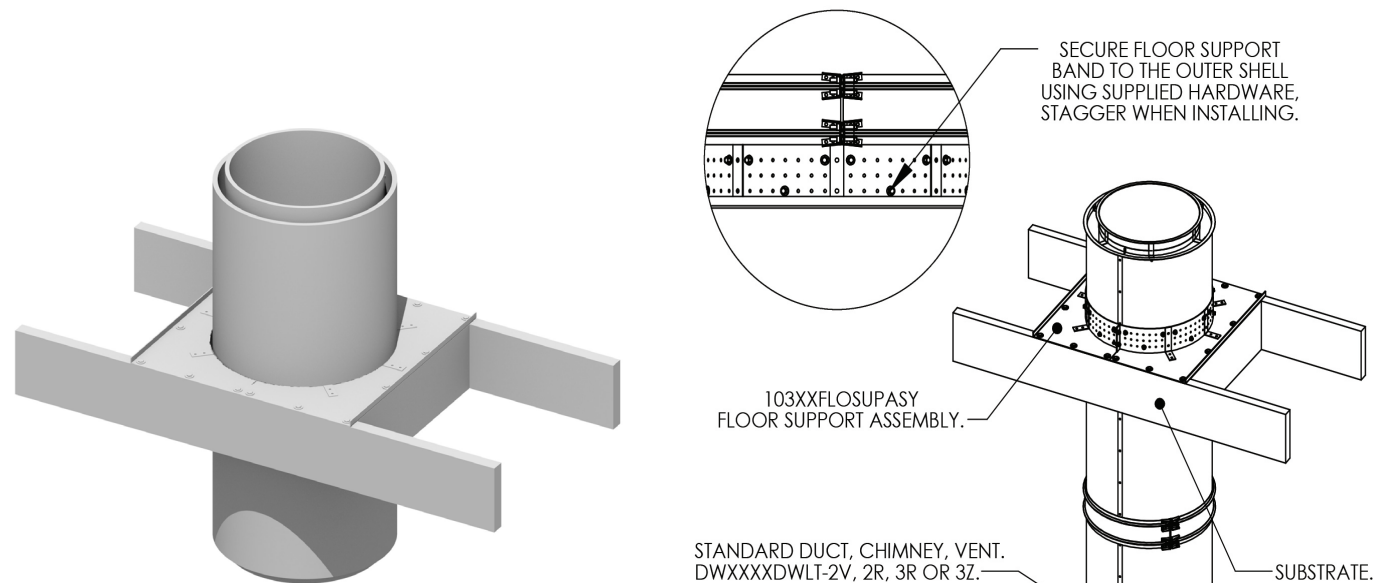

Vertical Duct Floor Support

VERTICAL SUPPORT SPACING FOR DOUBLE WALL WITH FLOOR SUPPORT						
DUCT DIAMETER	2 LAYER SHELL / DIM "A"	SUPPORT SPACING	FLOOR SUPPORT ASSEMBLY 2R, 2V	3 LAYER SHELL / DIM "A"	SUPPORT SPACING	FLOOR SUPPORT ASSEMBLY 3R, 3Z
8.00"	12" / 16 1/2"	24' FT	10312FLOSUPASY	14" / 18 1/2"	24' FT	10314FLOSUPASY
10.00"	14" / 18 1/2"	24' FT	10314FLOSUPASY	16" / 20 1/2"	24' FT	10316FLOSUPASY
12.00"	16" / 20 1/2"	24' FT	10316FLOSUPASY	18" / 22 1/2"	24' FT	10318FLOSUPASY
14.00"	18" / 22 1/2"	24' FT	10318FLOSUPASY	20" / 24 1/2"	24' FT	10320FLOSUPASY
16.00"	20" / 24 1/2"	24' FT	10320FLOSUPASY	22" / 26 1/2"	24' FT	10322FLOSUPASY
18.00"	N/A	N/A	N/A	24" / 28 1/2"	24' FT	10324FLOSUPASY
20.00"	N/A	N/A	N/A	26" / 30 1/2"	24' FT	10326FLOSUPASY
22.00"	N/A	N/A	N/A	28" / 32 1/2"	24' FT	10328FLOSUPASY
24.00"	N/A	N/A	N/A	30" / 34 1/2"	24' FT	10330FLOSUPASY

Vertical Duct Curb Support

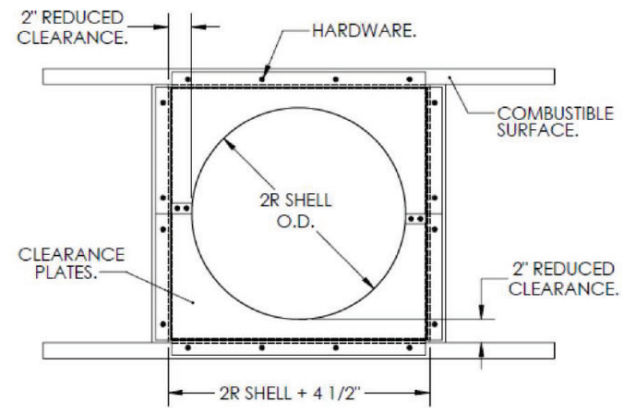
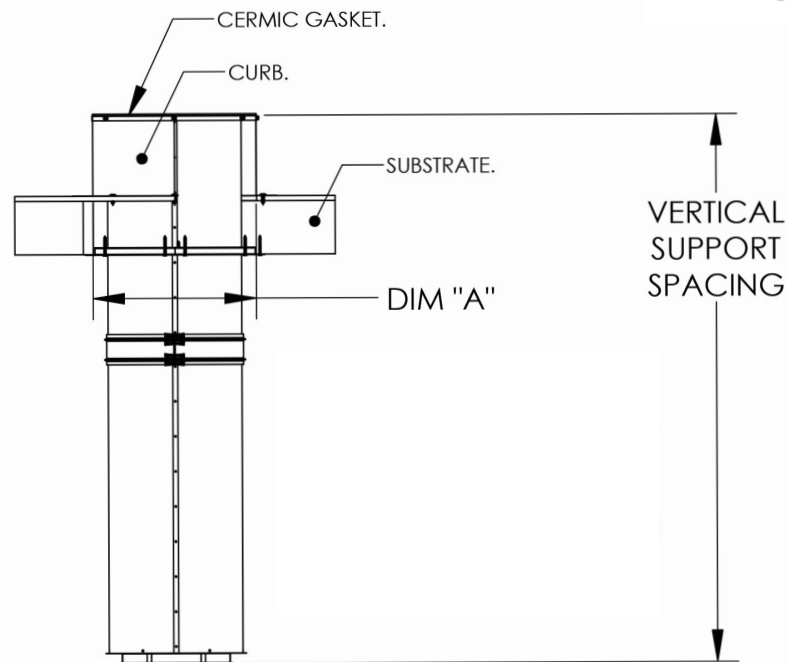
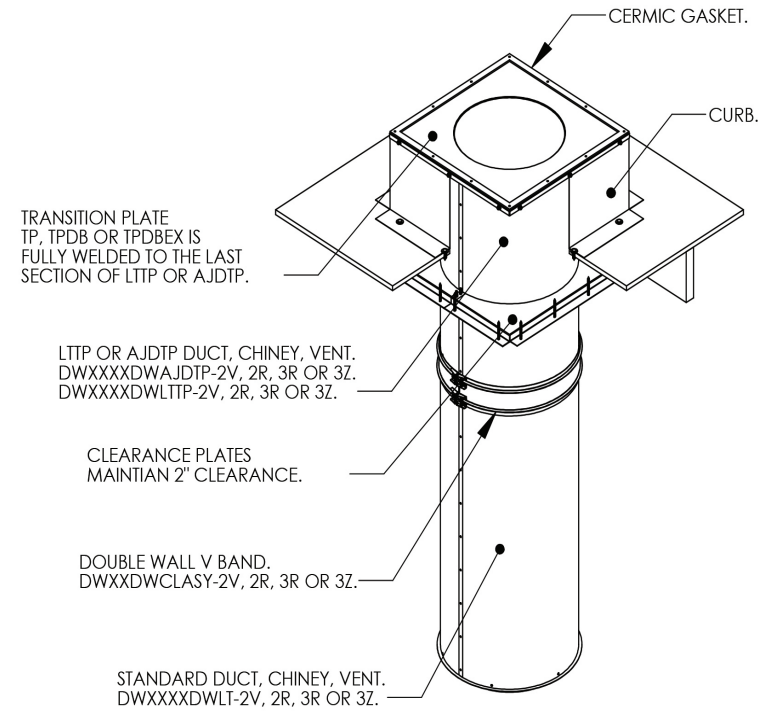
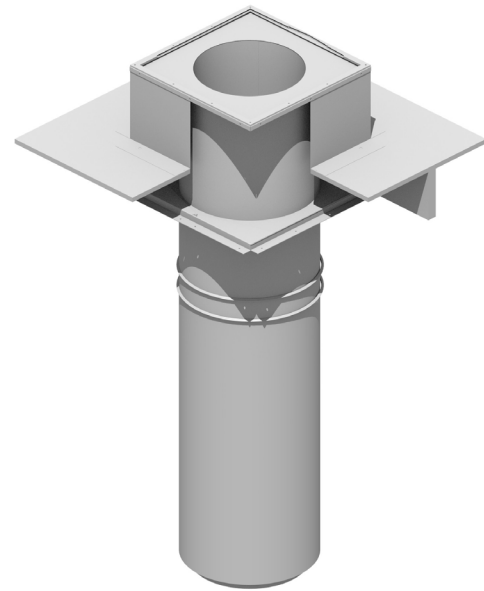

Vertical Duct Curb Support

VERTICAL SUPPORT SPACING FOR DOUBLE WALL WITH TP, TPDB, TPDBEX & CURB						
DUCT DIAMETER	2 LAYER SHELL / DIM "A"	SUPPORT SPACING	DOUBLE WALL DUCT 2R, 2V	3 LAYER SHELL / DIM "A"	SUPPORT SPACING	DOUBLE WALL DUCT 3R, 3Z
8.00"	12" / 16 1/2"	24' FT	DW08XXDWAJDTP / DW0845DWLTTP	14" / 18 1/2"	24' FT	DW08XXDWAJDTP / DW0845DWLTTP
10.00"	14" / 18 1/2"	24' FT	DW10XXDWAJDTP / DW1045DWLTTP	16" / 20 1/2"	24' FT	DW10XXDWAJDTP / DW1045DWLTTP
12.00"	16" / 20 1/2"	24' FT	DW12XXDWAJDTP / DW1245DWLTTP	18" / 22 1/2"	24' FT	DW12XXDWAJDTP / DW1245DWLTTP
14.00"	18" / 22 1/2"	24' FT	DW14XXDWAJDTP / DW1445DWLTTP	20" / 24 1/2"	24' FT	DW14XXDWAJDTP / DW1445DWLTTP
16.00"	20" / 24 1/2"	24' FT	DW16XXDWAJDTP / DW1645DWLTTP	22" / 26 1/2"	24' FT	DW16XXDWAJDTP / DW1645DWLTTP
18.00"	N/A	N/A	N/A	24" / 28 1/2"	24' FT	DW18XXDWAJDTP / DW1845DWLTTP
20.00"	N/A	N/A	N/A	26" / 30 1/2"	24' FT	DW20XXDWAJDTP / DW2045DWLTTP
22.00"	N/A	N/A	N/A	28" / 32 1/2"	24' FT	DW22XXDWAJDTP / DW2245DWLTTP
24.00"	N/A	N/A	N/A	30" / 34 1/2"	24' FT	DW24XXDWAJDTP / DW2445DWLTTP

Vertical Duct Wall Support

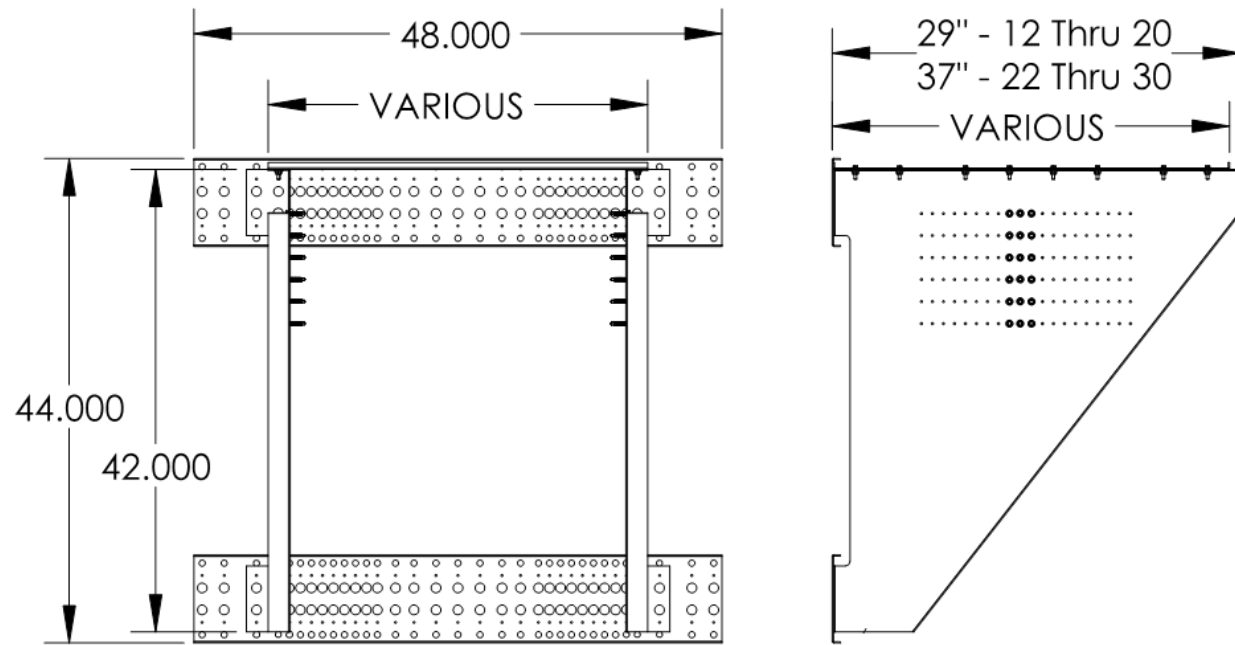
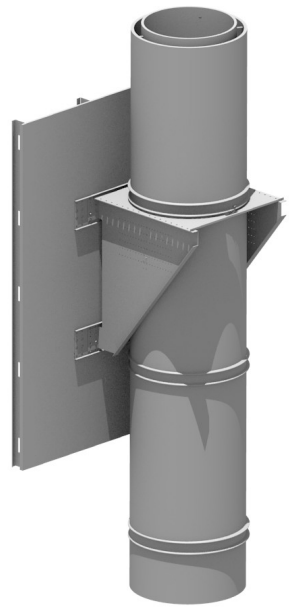

Vertical Duct Wall Support

VERTICAL SUPPORT SPACING & SUPPORT ASSEMBLY PART NUMBERS				
DUCT DIAMETER	SUPPORT SPACING 2R	SUPPORT SPACING	DOUBLE WALL DUCT 2R	DOUBLE WALL DUCT 3R & 3Z
8"	20'	10'	DW12DWVESU	DW14DWVESU
10"	20'	10'	DW14DWVESU	DW16DWVESU
12"	20'	10'	DW16DWVESU	DW18DWVESU
14"	20'	10'	DW18DWVESU	DW20DWVESU
16"	20'	10'	DW20DWVESU	DW22DWVESU
18"	N/A	10'	N/A	DW24DWVESU
20"	N/A	10'	N/A	DW26DWVESU
22"	N/A	10'	N/A	DW28DWVESU
24"	N/A	10'	N/A	DW30DWVESU

INSULATION LENGTHS PER NUMBER OF LAYERS / DIAMETERS				
Duct Diameter	2 Layers O.D.	2 Layer - Insulation Length	3 Layers O.D.	3 Layer - Insulation Length
8"	12"	72"	14"	116"
10"	14"	85"	16"	135"
12"	16"	97"	18"	154"
14"	18"	110"	20"	173"
16"	20"	122"	22"	191"
18"	N/A		24"	210"
20"	N/A		26"	229"
22"	N/A		28"	248"
24"	N/A		30"	267"

DW Fire Stop Assembly

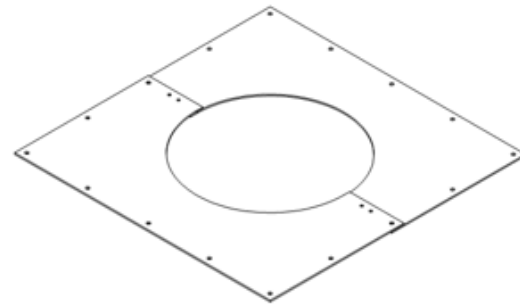
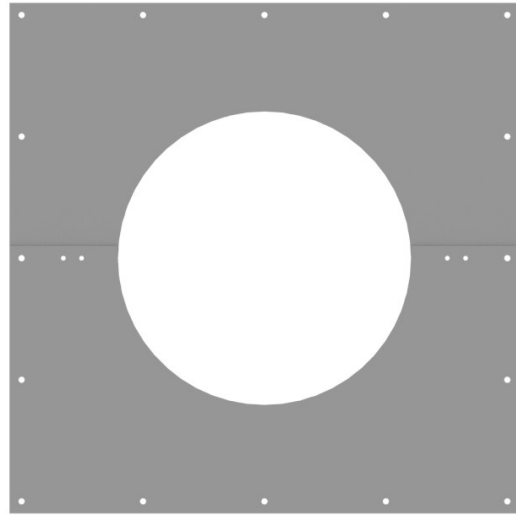

2 PARTS PER ASSEMBLY

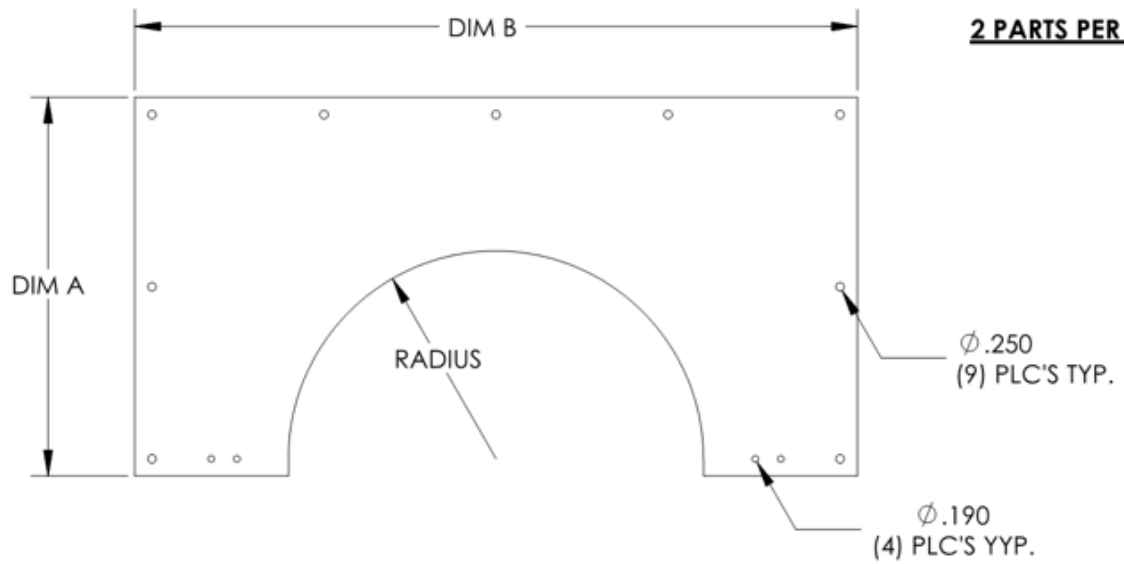

DW Fire Stop Assembly

DUCT INFORMATION				
Shell Diameter	Radius	Dim A	Dim B	Part Number
12"	6.031"	11.00"	21.00"	DW1221FIREPLATE
14"	7.031"	12.00"	23.00"	DW1423FIREPLATE
16"	8.031"	13.00"	25.00"	DW1625FIREPLATE
18"	9.031"	14.00"	27.00"	DW1827FIREPLATE
20"	10.031"	15.00"	29.00"	DW2029FIREPLATE
22"	11.031"	16.00"	31.00"	DW2231FIREPLATE
24"	12.031"	17.00"	33.00"	DW2433FIREPLATE
26"	13.031"	18.00"	35.00"	DW2635FIREPLATE
28"	14.031"	19.00"	37.00"	DW2837FIREPLATE
30"	15.031"	20.00"	39.00"	DW3039FIREPLATE

Horizontal Fire Stop Assembly

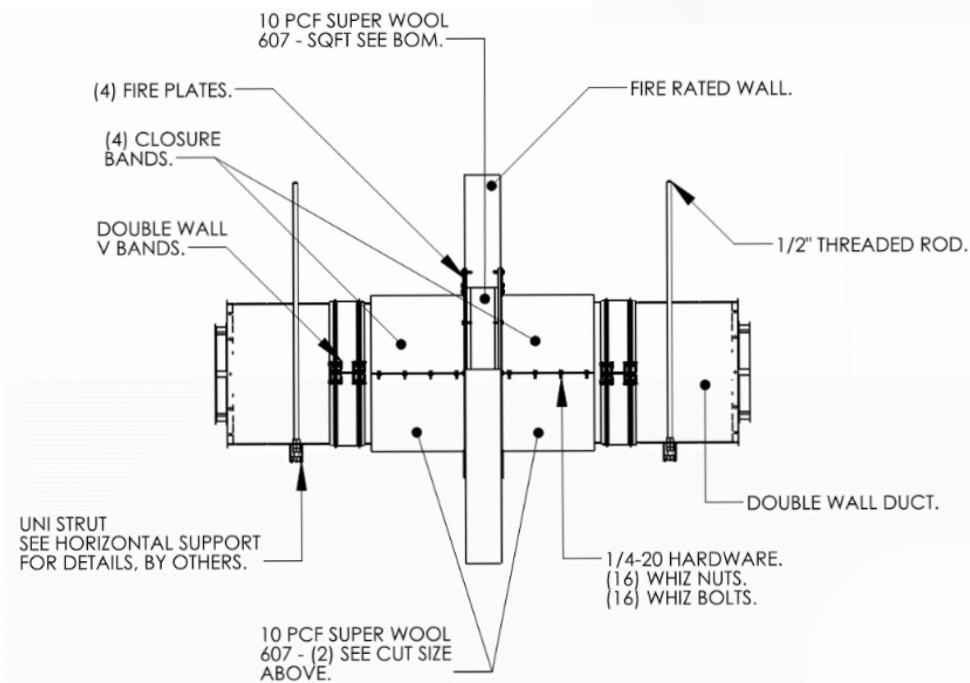
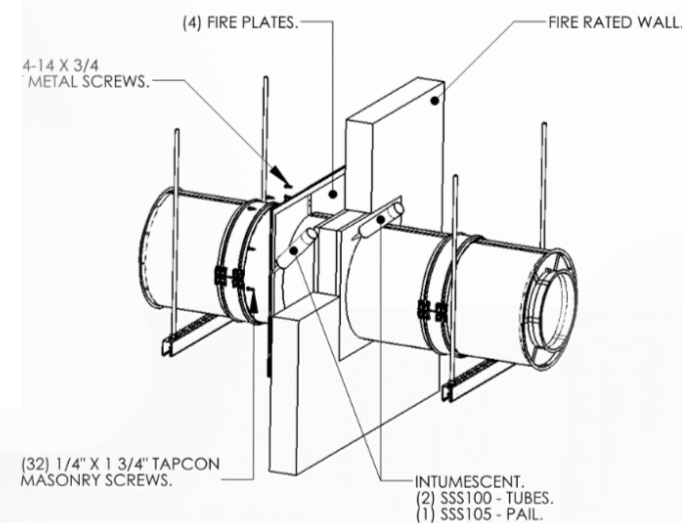
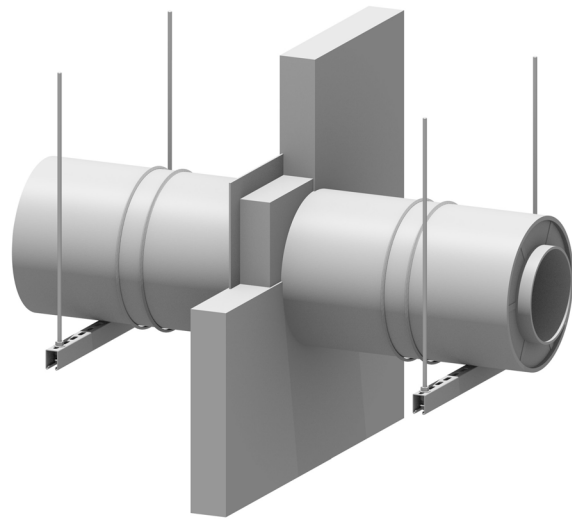

Horizontal Fire Stop Assembly

HORIZONTAL FIRE STOP KEY COMPONENTS

Part Number	Duct Diameter 2R	Fire Plates	Closure Bands	Duct Diameter 3R & 3Z
DW12HFIRESTOPKIT	8.00"	DW1221FIREPLATE	DW12DWCLBAND	N/A
DW14HFIRESTOPKIT	10.00"	DW1423FIREPLATE	DW14DWCLBAND	8.00"
DW16HFIRESTOPKIT	12.00"	DW1625FIREPLATE	DW16DWCLBAND	10.00"
DW18HFIRESTOPKIT	14.00"	DW1827FIREPLATE	DW18DWCLBAND	12.00"
DW20HFIRESTOPKIT	16.00"	DW2029FIREPLATE	DW20DWCLBAND	14.00"
DW22HFIRESTOPKIT	N/A	N/A	N/A	16.00"
DW24HFIRESTOPKIT	N/A	N/A	N/A	18.00"
DW26HFIRESTOPKIT	N/A	N/A	N/A	20.00"
DW28HFIRESTOPKIT	N/A	N/A	N/A	22.00"
DW30HFIRESTOPKIT	N/A	N/A	N/A	24.00"

HORIZONTAL FIRE STOP KEY COMPONENTS (CONT)

Fire Plates	Closure Bands	10 PCF Super Wool 607 Plus - Closure Band
N/A	N/A	12" X 42"
DW1423FIREPLATE	DW14DWCLBAND	12" X 49"
DW1625FIREPLATE	DW16DWCLBAND	12" X 55"
DW1827FIREPLATE	DW18DWCLBAND	12" X 61"
DW2029FIREPLATE	DW20DWCLBAND	12" X 67"
DW2231FIREPLATE	DW22DWCLBAND	12" X 74"
DW2433FIREPLATE	DW24DWCLBAND	12" X 80"
DW2635FIREPLATE	DW26DWCLBAND	12" X 86"
DW2837FIREPLATE	DW28DWCLBAND	12" X 92"
DW3039FIREPLATE	DW30DWCLBAND	12" X 99"

Vertical Fire Stop Assembly

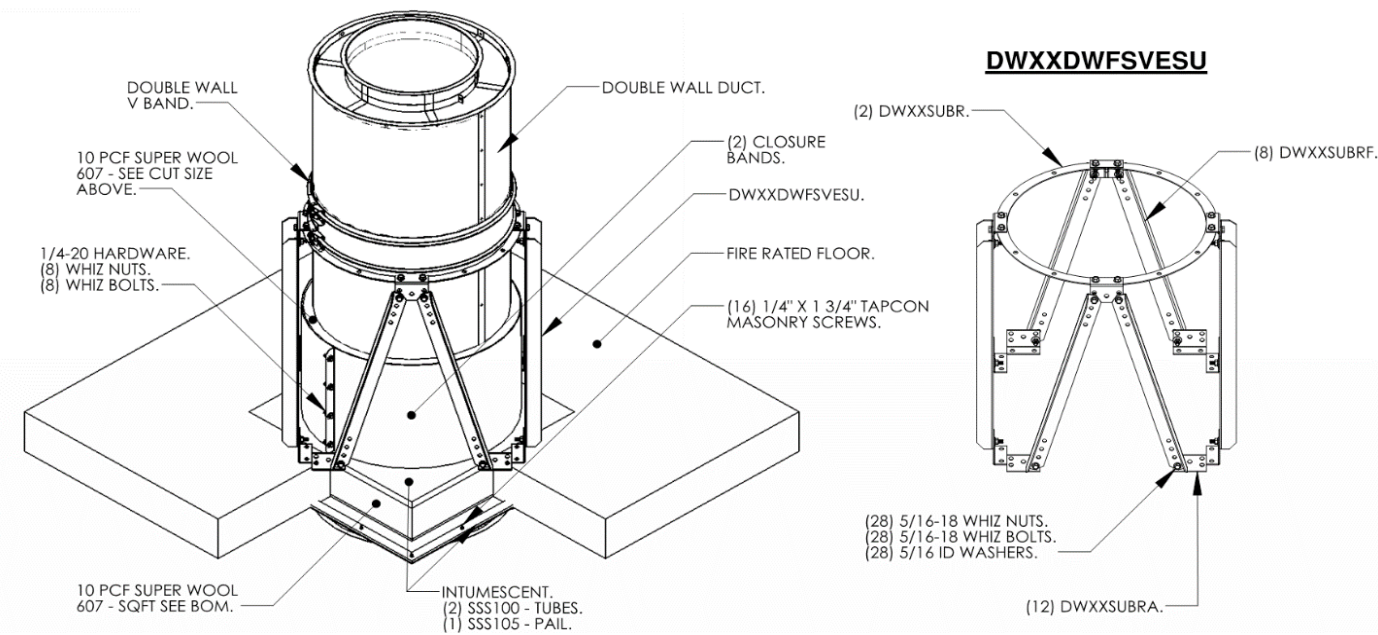
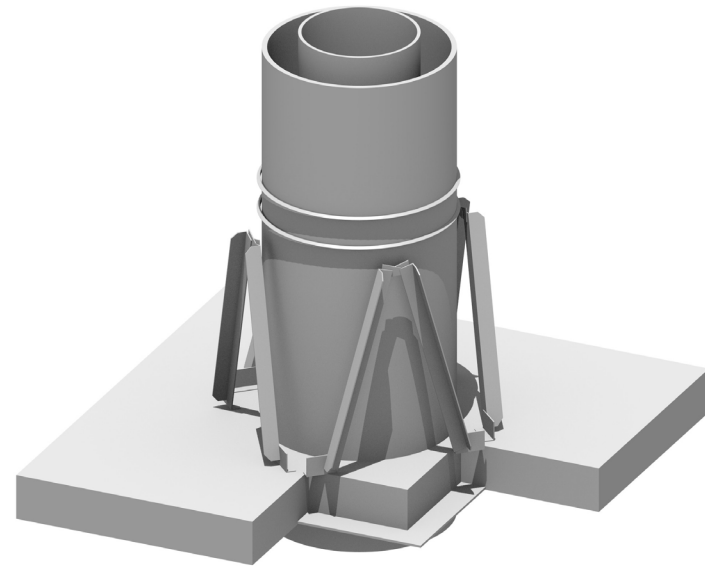

Vertical Fire Stop Assembly

VERTICAL FIRE STOP KEY COMPONENTS

Part Number	Duct Diameter 2R	Fire Plates	Closure Bands	Fire Stop Vertical Support
DW12VFIRESTOPKIT	8.00"	DW1221FIREPLATE	DW12DWCLBAND	DW12DWFSVESU
DW14VFIRESTOPKIT	10.00"	DW1423FIREPLATE	DW14DWCLBAND	DW14DWFSVESU
DW16VFIRESTOPKIT	12.00"	DW1625FIREPLATE	DW16DWCLBAND	DW16DWFSVESU
DW18VFIRESTOPKIT	14.00"	DW1827FIREPLATE	DW18DWCLBAND	DW18DWFSVESU
DW20VFIRESTOPKIT	16.00"	DW2029FIREPLATE	DW20DWCLBAND	DW20DWFSVESU
DW22VFIRESTOPKIT	N/A	N/A	N/A	N/A
DW24VFIRESTOPKIT	N/A	N/A	N/A	N/A
DW26VFIRESTOPKIT	N/A	N/A	N/A	N/A
DW28VFIRESTOPKIT	N/A	N/A	N/A	N/A
DW30VFIRESTOPKIT	N/A	N/A	N/A	N/A

VERTICAL FIRE STOP KEY COMPONENTS (CONT)

Duct Diameter 3R & 3Z	Fire Plates	Closure Bands	Fire Stop Vertical Support	10 PCF Super Wool 607 Plus - Closure Band
N/A	N/A	N/A	N/A	12" X 42"
8.00"	DW1423FIREPLATE	DW14DWCLBAND	DW14DWFSVESU	12" X 49"
10.00"	DW1625FIREPLATE	DW16DWCLBAND	DW16DWFSVESU	12" X 55"
12.00"	DW1827FIREPLATE	DW18DWCLBAND	DW18DWFSVESU	12" X 61"
14.00"	DW2029FIREPLATE	DW20DWCLBAND	DW20DWFSVESU	12" X 67"
16.00"	DW2231FIREPLATE	DW22DWCLBAND	DW22DWFSVESU	12" X 74"
18.00"	DW2433FIREPLATE	DW24DWCLBAND	DW24DWFSVESU	12" X 80"
20.00"	DW2635FIREPLATE	DW26DWCLBAND	DW26DWFSVESU	12" X 86"
22.00"	DW2837FIREPLATE	DW28DWCLBAND	DW28DWFSVESU	12" X 92"
24.00"	DW3039FIREPLATE	DW30DWCLBAND	DW30DWFSVESU	12" X 99"

Appendix A

Duct Diameter Sizing Charts

The following is needed to determine the duct velocity: CFM and Area (Velocity = CFM/Area). In the chart below, the green selections indicate ideal design velocities, the yellow selections indicate fair design velocities and the red selections indicate bad design velocities. Velocities should never be designed in the red areas of the chart. Duct should be sized so that the velocity is between 500 and 2500 fpm. NFPA 96 requires a minimum duct velocity of 500 fpm. Always take the size of the fan curve into consideration when sizing duct. Under-sizing or over-sizing duct will cause system effect and or interfere with the fan curb."

Appendix A

Duct Diameter Sizing Charts

DUCT VELOCITIES									
INNER DIAMETER (IN)									
CFM	8	10	12	14	16	18	20	22	24
100	286	183	127	94	72	57	46	38	32
200	573	367	255	187	143	113	92	76	64
300	859	550	382	281	215	170	138	114	95
400	1146	733	509	374	286	226	183	152	127
500	1432	917	637	468	358	283	229	189	159
600	1719	1100	764	561	430	340	275	227	191
700	2005	1283	891	655	501	396	321	265	223
800	2292	1467	1019	748	573	453	367	303	255
900	2578	1650	1146	842	645	509	413	341	286
1000	2865	1833	1273	935	716	566	458	379	318
1100	3151	2017	1401	1029	788	622	504	417	350
1200	3438	2200	1528	1123	859	679	550	455	382
1300	3724	2384	1655	1216	931	736	596	492	414
1400	4011	2567	1783	1310	1003	792	642	530	446
1500	4297	2750	1910	1403	1074	849	688	568	477
1600	4584	2934	2037	1497	1146	905	733	606	509
1700	4870	3117	2165	1590	1218	962	779	644	541
1800	5157	3300	2292	1684	1289	1019	825	682	573
1900	5443	3484	2419	1777	1361	1075	871	720	605
2000	5730	3667	2546	1871	1432	1132	917	758	637
2100	6016	3850	2674	1964	1504	1188	963	796	668
2200	6303	4034	2801	2058	1576	1245	1008	833	700
2300	6589	4217	2928	2152	1647	1302	1054	871	732
2400	6875	4400	3056	2245	1719	1358	1100	909	764
2500	7162	4584	3183	2339	1790	1415	1146	947	796
2600	7448	4767	3310	2432	1862	1471	1192	985	828
2700	7735	4950	3438	2526	1934	1528	1238	1023	859
2800	8021	5134	3565	2619	2005	1584	1283	1061	891
2900	8308	5317	3692	2713	2077	1641	1329	1099	923
3000	8594	5500	3820	2806	2149	1698	1375	1136	955

Appendix A

Duct Diameter Sizing Charts

DUCT VELOCITIES									
INNER DIAMETER (IN)									
CFM	8	10	12	14	16	18	20	22	24
3100	8881	5684	3947	2900	2220	1754	1421	1174	987
3200	9167	5867	4074	2993	2292	1811	1467	1212	1019
3300	9454	6050	4202	3087	2363	1867	1513	1250	1050
3400	9740	6234	4329	3181	2435	1924	1558	1288	1082
3500	10027	6417	4456	3274	2507	1981	1604	1326	1114
3600	10313	6600	4584	3368	2578	2037	1650	1364	1146
3700	10600	6784	4711	3461	2650	2094	1696	1402	1178
3800	10886	6967	4838	3555	2722	2150	1742	1439	1210
3900	11173	7151	4966	3648	2793	2207	1788	1477	1241
4000	11459	7334	5093	3742	2865	2264	1833	1515	1273
4100	11746	7517	5220	3835	2936	2320	1879	1553	1305
4200	12032	7701	5348	3929	3008	2377	1925	1591	1337
4300	12319	7884	5475	4022	3080	2433	1971	1629	1369
4400	12605	8067	5602	4116	3151	2490	2017	1667	1401
4500	12892	8251	5730	4209	3223	2546	2063	1705	1432
4600	13178	8434	5857	4303	3295	2603	2108	1743	1464
4700	13465	8617	5984	4397	3366	2660	2154	1780	1496
4800	13751	8801	6112	4490	3438	2716	2200	1818	1528
4900	14037	8984	6239	4584	3509	2773	2246	1856	1560
5000	14324	9167	6366	4677	3581	2829	2292	1894	1592
5100	14610	9351	6494	4771	3653	2886	2338	1932	1623
5200	14897	9534	6621	4864	3724	2943	2384	1970	1655
5300	15183	9717	6748	4958	3796	2999	2429	2008	1687
5400	15470	9901	6875	5051	3867	3056	2475	2046	1719
5500	15756	10084	7003	5145	3939	3112	2521	2083	1751
5600	16043	10267	7130	5238	4011	3169	2567	2121	1783
5700	16329	10451	7257	5332	4082	3226	2613	2159	1814
5800	16616	10634	7385	5426	4154	3282	2659	2197	1846
5900	16902	10817	7512	5519	4226	3339	2704	2235	1878
6000	17189	11001	7639	5613	4297	3395	2750	2273	1910
6100	17475	11184	7767	5706	4369	3452	2796	2311	1942
6200	17762	11367	7894	5800	4440	3508	2842	2349	1974
6300	18048	11551	8021	5893	4512	3565	2888	2387	2005

Appendix A

Duct Diameter Sizing Charts

DUCT VELOCITIES									
INNER DIAMETER (IN)									
CFM	8	10	12	14	16	18	20	22	24
6400	18335	11734	8149	5987	4584	3622	2934	2424	2037
6500	18621	11918	8276	6080	4655	3678	2979	2462	2069
6600	18908	12101	8403	6174	4727	3735	3025	2500	2101
6700	19194	12284	8531	6267	4799	3791	3071	2538	2133
6800	19481	12468	8658	6361	4870	3848	3117	2576	2165
6900	19767	12651	8785	6455	4942	3905	3163	2614	2196
7000	20054	12834	8913	6548	5013	3961	3209	2652	2228
7100	20340	13018	9040	6642	5085	4018	3254	2690	2260
7200	20626	13201	9167	6735	5157	4074	3300	2727	2292
7300	20913	13384	9295	6829	5228	4131	3346	2765	2324
7400	21199	13568	9422	6922	5300	4188	3392	2803	2355
7500	21486	13751	9549	7016	5371	4244	3438	2841	2387
7600	21772	13934	9677	7109	5443	4301	3484	2879	2419
7700	22059	14118	9804	7203	5515	4357	3529	2917	2451
7800	22345	14301	9931	7296	5586	4414	3575	2955	2483
7900	22632	14484	10059	7390	5658	4470	3621	2993	2515
8000	22918	14668	10186	7484	5730	4527	3667	3031	2546
8100	23205	14851	10313	7577	5801	4584	3713	3068	2578
8200	23491	15034	10441	7671	5873	4640	3759	3106	2610
8300	23778	15218	10568	7764	5944	4697	3804	3144	2642
8400	24064	15401	10695	7858	6016	4753	3850	3182	2674
8500	24351	15584	10823	7951	6088	4810	3896	3220	2706
8600	24637	15768	10950	8045	6159	4867	3942	3258	2737
8700	24924	15951	11077	8138	6231	4923	3988	3296	2769
8800	6303	4034	2801	2058	1576	1245	1008	833	700
8900	6374	4079	2833	2081	1594	1259	1020	843	708
9000	6446	4125	2865	2105	1611	1273	1031	852	716
9100	6517	4171	2897	2128	1629	1287	1043	862	724
9200	6589	4217	2928	2152	1647	1302	1054	871	732
9300	6661	4263	2960	2175	1665	1316	1066	881	740
9400	6732	4309	2992	2198	1683	1330	1077	890	748
9500	6804	4354	3024	2222	1701	1344	1089	900	756
9600	6875	4400	3056	2245	1719	1358	1100	909	764

Appendix A

Duct Diameter Sizing Charts

DUCT VELOCITIES									
INNER DIAMETER (IN)									
CFM	8	10	12	14	16	18	20	22	24
9700	6947	4446	3088	2268	1737	1372	1112	919	772
9800	7019	4492	3119	2292	1755	1386	1123	928	780
9900	7090	4538	3151	2315	1773	1401	1134	938	788
10000	7162	4584	3183	2339	1790	1415	1146	947	796
10100	7234	4629	3215	2362	1808	1429	1157	957	804
10200	7305	4675	3247	2385	1826	1443	1169	966	812
10300	7377	4721	3279	2409	1844	1457	1180	975	820
10400	7448	4767	3310	2432	1862	1471	1192	985	828
10500	7520	4813	3342	2456	1880	1485	1203	994	836
10600	7592	4859	3374	2479	1898	1500	1215	1004	844
10700	7663	4905	3406	2502	1916	1514	1226	1013	851
10800	7735	4950	3438	2526	1934	1528	1238	1023	859
10900	7807	4996	3470	2549	1952	1542	1249	1032	867
11000	7878	5042	3501	2572	1970	1556	1261	1042	875
11100	7950	5088	3533	2596	1987	1570	1272	1051	883
11200	8021	5134	3565	2619	2005	1584	1283	1061	891
11300	8093	5180	3597	2643	2023	1599	1295	1070	899
11400	8165	5225	3629	2666	2041	1613	1306	1080	907
11500	8236	5271	3661	2689	2059	1627	1318	1089	915
11600	8308	5317	3692	2713	2077	1641	1329	1099	923
11700	8380	5363	3724	2736	2095	1655	1341	1108	931
11800	8451	5409	3756	2760	2113	1669	1352	1118	939
11900	8523	5455	3788	2783	2131	1684	1364	1127	947
12000	8594	5500	3820	2806	2149	1698	1375	1136	955
12100	8666	5546	3852	2830	2166	1712	1387	1146	963
12200	8738	5592	3883	2853	2184	1726	1398	1155	971
12300	8809	5638	3915	2876	2202	1740	1409	1165	979
12400	8881	5684	3947	2900	2220	1754	1421	1174	987
12500	8952	5730	3979	2923	2238	1768	1432	1184	995
12600	9024	5775	4011	2947	2256	1783	1444	1193	1003
12700	9096	5821	4043	2970	2274	1797	1455	1203	1011
12800	9167	5867	4074	2993	2292	1811	1467	1212	1019
12900	9239	5913	4106	3017	2310	1825	1478	1222	1027

Appendix A

Duct Diameter Sizing Charts

DUCT VELOCITIES									
INNER DIAMETER (IN)									
CFM	8	10	12	14	16	18	20	22	24
13000	9311	5959	4138	3040	2328	1839	1490	1231	1035
13100	9382	6005	4170	3064	2346	1853	1501	1241	1042
13200	9454	6050	4202	3087	2363	1867	1513	1250	1050
13300	9525	6096	4234	3110	2381	1882	1524	1260	1058
13400	9597	6142	4265	3134	2399	1896	1536	1269	1066
13500	9669	6188	4297	3157	2417	1910	1547	1279	1074
13600	9740	6234	4329	3181	2435	1924	1558	1288	1082
13700	9812	6280	4361	3204	2453	1938	1570	1297	1090
13800	9884	6325	4393	3227	2471	1952	1581	1307	1098
13900	9955	6371	4425	3251	2489	1966	1593	1316	1106
14000	10027	6417	4456	3274	2507	1981	1604	1326	1114
14100	10098	6463	4488	3297	2525	1995	1616	1335	1122
14200	10170	6509	4520	3321	2543	2009	1627	1345	1130
14300	10242	6555	4552	3344	2560	2023	1639	1354	1138
14400	10313	6600	4584	3368	2578	2037	1650	1364	1146
14500	10385	6646	4615	3391	2596	2051	1662	1373	1154
14600	10456	6692	4647	3414	2614	2065	1673	1383	1162
14700	10528	6738	4679	3438	2632	2080	1684	1392	1170
14800	10600	6784	4711	3461	2650	2094	1696	1402	1178
14900	10671	6830	4743	3485	2668	2108	1707	1411	1186
15000	10743	6875	4775	3508	2686	2122	1719	1421	1194
15100	10815	6921	4806	3531	2704	2136	1730	1430	1202
15200	10886	6967	4838	3555	2722	2150	1742	1439	1210
15300	10958	7013	4870	3578	2739	2165	1753	1449	1218
15400	11029	7059	4902	3601	2757	2179	1765	1458	1225
15500	11101	7105	4934	3625	2775	2193	1776	1468	1233
15600	11173	7151	4966	3648	2793	2207	1788	1477	1241
15700	11244	7196	4997	3672	2811	2221	1799	1487	1249
15800	11316	7242	5029	3695	2829	2235	1811	1496	1257
15900	11388	7288	5061	3718	2847	2249	1822	1506	1265
16000	11459	7334	5093	3742	2865	2264	1833	1515	1273
16100	11531	7380	5125	3765	2883	2278	1845	1525	1281
16200	11602	7426	5157	3789	2901	2292	1856	1534	1289

Appendix A

Duct Diameter Sizing Charts

DUCT VELOCITIES									
INNER DIAMETER (IN)									
CFM	8	10	12	14	16	18	20	22	24
16300	11674	7471	5188	3812	2919	2306	1868	1544	1297
16400	11746	7517	5220	3835	2936	2320	1879	1553	1305
16500	11817	7563	5252	3859	2954	2334	1891	1563	1313
16600	11889	7609	5284	3882	2972	2348	1902	1572	1321
16700	11960	7655	5316	3905	2990	2363	1914	1582	1329
16800	12032	7701	5348	3929	3008	2377	1925	1591	1337
16900	12104	7746	5379	3952	3026	2391	1937	1600	1345
17000	12175	7792	5411	3976	3044	2405	1948	1610	1353
17100	12247	7838	5443	3999	3062	2419	1960	1619	1361
17200	12319	7884	5475	4022	3080	2433	1971	1629	1369
17300	12390	7930	5507	4046	3098	2447	1982	1638	1377
17400	12462	7976	5539	4069	3115	2462	1994	1648	1385
17500	12533	8021	5570	4093	3133	2476	2005	1657	1393
17600	12605	8067	5602	4116	3151	2490	2017	1667	1401
17700	12677	8113	5634	4139	3169	2504	2028	1676	1409
17800	12748	8159	5666	4163	3187	2518	2040	1686	1416
17900	12820	8205	5698	4186	3205	2532	2051	1695	1424
18000	12892	8251	5730	4209	3223	2546	2063	1705	1432
18100	12963	8296	5761	4233	3241	2561	2074	1714	1440
18200	13035	8342	5793	4256	3259	2575	2086	1724	1448
18300	13106	8388	5825	4280	3277	2589	2097	1733	1456
18400	13178	8434	5857	4303	3295	2603	2108	1743	1464
18500	13250	8480	5889	4326	3312	2617	2120	1752	1472
18600	13321	8526	5921	4350	3330	2631	2131	1761	1480
18700	13393	8571	5952	4373	3348	2646	2143	1771	1488
18800	13465	8617	5984	4397	3366	2660	2154	1780	1496
18900	13536	8663	6016	4420	3384	2674	2166	1790	1504
19000	13608	8709	6048	4443	3402	2688	2177	1799	1512
19100	13679	8755	6080	4467	3420	2702	2189	1809	1520
19200	13751	8801	6112	4490	3438	2716	2200	1818	1528
19300	13823	8846	6143	4514	3456	2730	2212	1828	1536
19400	13894	8892	6175	4537	3474	2745	2223	1837	1544
19500	13966	8938	6207	4560	3491	2759	2235	1847	1552

Appendix A

Duct Diameter Sizing Charts

DUCT VELOCITIES									
INNER DIAMETER (IN)									
CFM	8	10	12	14	16	18	20	22	24
19600	14037	8984	6239	4584	3509	2773	2246	1856	1560
19700	14109	9030	6271	4607	3527	2787	2257	1866	1568
19800	14181	9076	6303	4630	3545	2801	2269	1875	1576
19900	14252	9121	6334	4654	3563	2815	2280	1885	1584
20000	14324	9167	6366	4677	3581	2829	2292	1894	1592
20100	14396	9213	6398	4701	3599	2844	2303	1904	1600
20200	14467	9259	6430	4724	3617	2858	2315	1913	1607
20300	14539	9305	6462	4747	3635	2872	2326	1922	1615
20400	14610	9351	6494	4771	3653	2886	2338	1932	1623
20500	14682	9397	6525	4794	3671	2900	2349	1941	1631
20600	14754	9442	6557	4818	3688	2914	2361	1951	1639
20700	14825	9488	6589	4841	3706	2928	2372	1960	1647
20800	14897	9534	6621	4864	3724	2943	2384	1970	1655
20900	14969	9580	6653	4888	3742	2957	2395	1979	1663
21000	15040	9626	6685	4911	3760	2971	2406	1989	1671
21100	15112	9672	6716	4934	3778	2985	2418	1998	1679
21200	15183	9717	6748	4958	3796	2999	2429	2008	1687
21300	15255	9763	6780	4981	3814	3013	2441	2017	1695
21400	15327	9809	6812	5005	3832	3027	2452	2027	1703
21500	15398	9855	6844	5028	3850	3042	2464	2036	1711
21600	15470	9901	6875	5051	3867	3056	2475	2046	1719
21700	15541	9947	6907	5075	3885	3070	2487	2055	1727
21800	15613	9992	6939	5098	3903	3084	2498	2065	1735
21900	15685	10038	6971	5122	3921	3098	2510	2074	1743
22000	15756	10084	7003	5145	3939	3112	2521	2083	1751
22100	15828	10130	7035	5168	3957	3127	2532	2093	1759
22200	15900	10176	7066	5192	3975	3141	2544	2102	1767
22300	15971	10222	7098	5215	3993	3155	2555	2112	1775
22400	16043	10267	7130	5238	4011	3169	2567	2121	1783
22500	16114	10313	7162	5262	4029	3183	2578	2131	1790
22600	16186	10359	7194	5285	4047	3197	2590	2140	1798
22700	16258	10405	7226	5309	4064	3211	2601	2150	1806
22800	16329	10451	7257	5332	4082	3226	2613	2159	1814

Appendix A

Duct Diameter Sizing Charts

DUCT VELOCITIES									
INNER DIAMETER (IN)									
CFM	8	10	12	14	16	18	20	22	24
22900	16401	10497	7289	5355	4100	3240	2624	2169	1822
23000	16473	10542	7321	5379	4118	3254	2636	2178	1830
23100	16544	10588	7353	5402	4136	3268	2647	2188	1838
23200	16616	10634	7385	5426	4154	3282	2659	2197	1846
23300	16687	10680	7417	5449	4172	3296	2670	2207	1854
23400	16759	10726	7448	5472	4190	3310	2681	2216	1862
23500	16831	10772	7480	5496	4208	3325	2693	2226	1870
23600	16902	10817	7512	5519	4226	3339	2704	2235	1878
23700	16974	10863	7544	5542	4243	3353	2716	2244	1886
23800	17045	10909	7576	5566	4261	3367	2727	2254	1894
23900	17117	10955	7608	5589	4279	3381	2739	2263	1902
24000	17189	11001	7639	5613	4297	3395	2750	2273	1910
24100	17260	11047	7671	5636	4315	3409	2762	2282	1918
24200	17332	11092	7703	5659	4333	3424	2773	2292	1926
24300	17404	11138	7735	5683	4351	3438	2785	2301	1934
24400	17475	11184	7767	5706	4369	3452	2796	2311	1942
24500	17547	11230	7799	5730	4387	3466	2807	2320	1950
24600	17618	11276	7830	5753	4405	3480	2819	2330	1958
24700	17690	11322	7862	5776	4423	3494	2830	2339	1966
24800	17762	11367	7894	5800	4440	3508	2842	2349	1974
24900	17833	11413	7926	5823	4458	3523	2853	2358	1981
25000	17905	11459	7958	5847	4476	3537	2865	2368	1989
25100	17977	11505	7990	5870	4494	3551	2876	2377	1997
25200	18048	11551	8021	5893	4512	3565	2888	2387	2005
25300	18120	11597	8053	5917	4530	3579	2899	2396	2013
25400	18191	11643	8085	5940	4548	3593	2911	2405	2021
25500	18263	11688	8117	5963	4566	3608	2922	2415	2029
25600	18335	11734	8149	5987	4584	3622	2934	2424	2037
25700	18406	11780	8181	6010	4602	3636	2945	2434	2045
25800	18478	11826	8212	6034	4619	3650	2956	2443	2053
25900	18550	11872	8244	6057	4637	3664	2968	2453	2061
26000	18621	11918	8276	6080	4655	3678	2979	2462	2069
26100	18693	11963	8308	6104	4673	3692	2991	2472	2077

Appendix A

Duct Diameter Sizing Charts

DUCT VELOCITIES									
INNER DIAMETER (IN)									
CFM	8	10	12	14	16	18	20	22	24
26200	18764	12055	8372	6151	4709	3721	3014	2481	2117
26300	18836	12101	8403	6174	4727	3735	3025	2491	2125
26400	18908	12147	8435	6197	4745	3749	3037	2500	2133
26500	18979	12193	8467	6221	4763	3763	3048	2510	2141
26600	19051	12238	8499	6244	4781	3777	3060	2519	2149
26700	19122	12284	8531	6267	4799	3791	3071	2529	2157
26800	19194	12330	8563	6291	4816	3806	3083	2538	2165
26900	19266	12376	8594	6314	4834	3820	3094	2548	2172
27000	19337	12422	8626	6338	4852	3834	3105	2557	2180
27100	19409	12468	8658	6361	4870	3848	3117	2566	2188
27200	19481	12513	8690	6384	4888	3862	3128	2576	2196
27300	19552	12559	8722	6408	4906	3876	3140	2585	2204
27400	19624	12605	8754	6431	4924	3890	3151	2595	2212
27500	19695	12651	8785	6455	4942	3905	3163	2604	2220
27600	19767	12697	8817	6478	4960	3919	3174	2614	2228
27700	19839	12743	8849	6501	4978	3933	3186	2623	2236
27800	19910	12788	8881	6525	4995	3947	3197	2633	2244
27900	19982	12834	8913	6548	5013	3961	3209	2642	2252
28000	20054	12880	8945	6571	5031	3975	3220	2652	2260
28100	20125	12926	8976	6595	5049	3989	3231	2661	2268
28200	20197	12972	9008	6618	5067	4004	3243	2671	2276
28300	20268	13018	9040	6642	5085	4018	3254	2680	2284
28400	20340	13063	9072	6665	5103	4032	3266	2690	2292
28500	20412	13109	9104	6688	5121	4046	3277	2699	2300
28600	20483	13155	9135	6712	5139	4060	3289	2709	2308
28700	20555	13201	9167	6735	5157	4074	3300	2718	2316
28800	20626	13247	9199	6759	5175	4089	3312	2727	2324
28900	20698	13293	9231	6782	5192	4103	3323	2737	2332
29000	20770	13338	9263	6805	5210	4117	3335	2746	2340
29100	20841	13384	9295	6829	5228	4131	3346	2756	2053
29200	20913	13430	9326	6852	5246	4145	3358	2765	2061
29300	20985	13476	9358	6875	5264	4159	3369	2775	2069
29400	21056	11963	8308	6104	4673	3692	2991	2784	2077

Appendix A

Duct Diameter Sizing Charts

DUCT VELOCITIES									
INNER DIAMETER (IN)									
CFM	8	10	12	14	16	18	20	22	24
29500	21128	13522	9390	6899	5282	4173	3380	2794	2348
29600	21199	13568	9422	6922	5300	4188	3392	2803	2355
29700	21271	13613	9454	6946	5318	4202	3403	2813	2363
29800	21343	13659	9486	6969	5336	4216	3415	2822	2371
29900	21414	13705	9517	6992	5354	4230	3426	2832	2379
30000	21486	13751	9549	7016	5371	4244	3438	2841	2387
30100	21558	13797	9581	7039	5389	4258	3449	2851	2395
30200	21629	13843	9613	7063	5407	4272	3461	2860	2403
30300	21701	13888	9645	7086	5425	4287	3472	2870	2411
30400	21772	13934	9677	7109	5443	4301	3484	2879	2419
30500	21844	13980	9708	7133	5461	4315	3495	2888	2427
30600	21916	14026	9740	7156	5479	4329	3507	2898	2435
30700	21987	14072	9772	7180	5497	4343	3518	2907	2443
30800	22059	14118	9804	7203	5515	4357	3529	2917	2451
30900	22130	14164	9836	7226	5533	4371	3541	2926	2459
31000	22202	14209	9868	7250	5551	4386	3552	2936	2467
31100	22274	14255	9899	7273	5568	4400	3564	2945	2475
31200	22345	14301	9931	7296	5586	4414	3575	2955	2483
31300	22417	14347	9963	7320	5604	4428	3587	2964	2491
31400	22489	14393	9995	7343	5622	4442	3598	2974	2499
31500	22560	14439	10027	7367	5640	4456	3610	2983	2507
31600	22632	14484	10059	7390	5658	4470	3621	2993	2515
31700	22703	14530	10090	7413	5676	4485	3633	3002	2523
31800	22775	14576	10122	7437	5694	4499	3644	3012	2531
31900	22847	14622	10154	7460	5712	4513	3655	3021	2539
32000	22918	14668	10186	7484	5730	4527	3667	3031	2546

Grease Duct Field Sheet

Use Area to Sketch Rise, Run, and Estimated Design

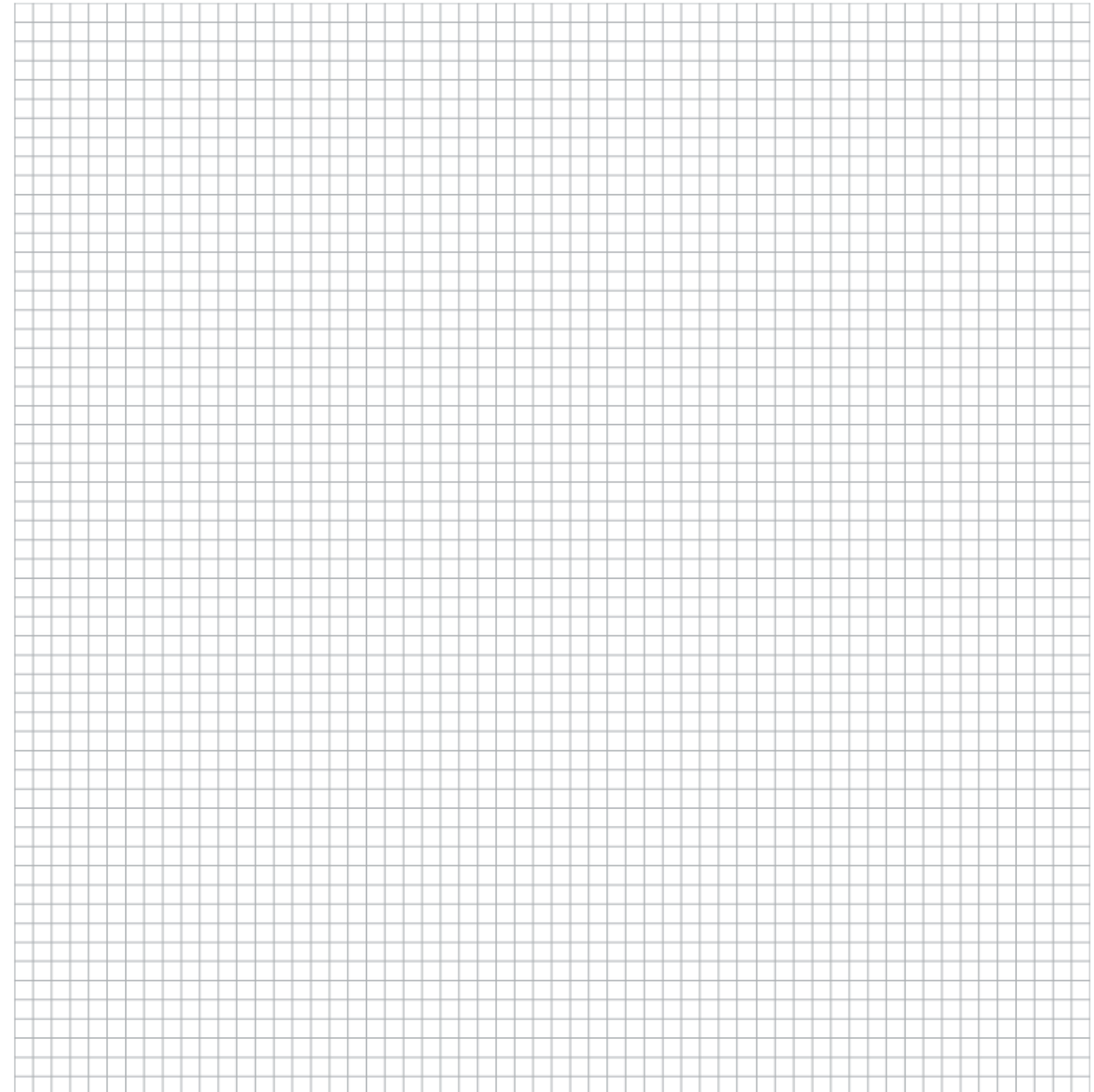

Grease Duct Field Sheet

Use Area to Sketch Rise, Run, and Estimated Design

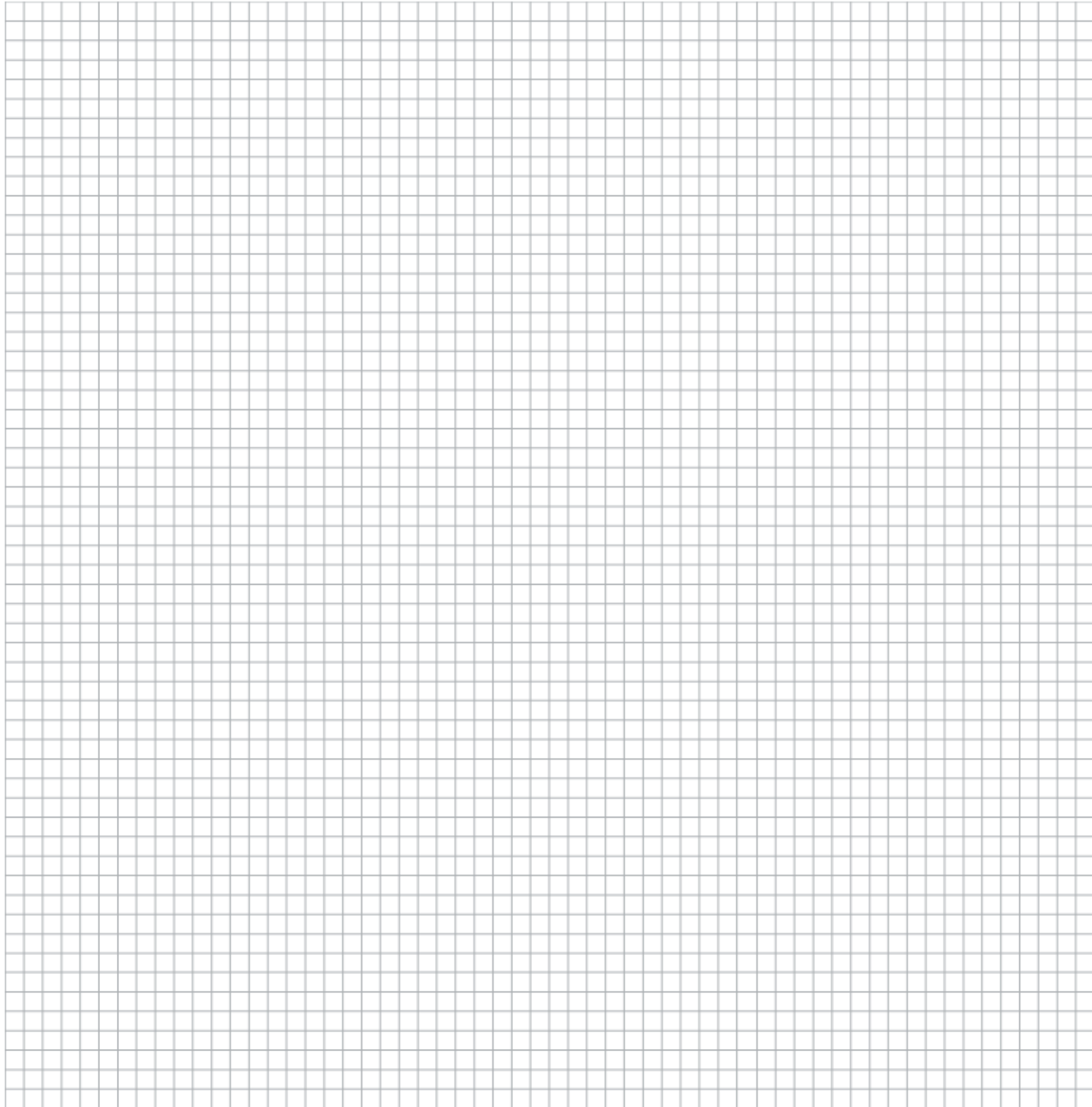

Grease Duct Field Sheet

Use Area to Sketch Rise, Run, and Estimated Design

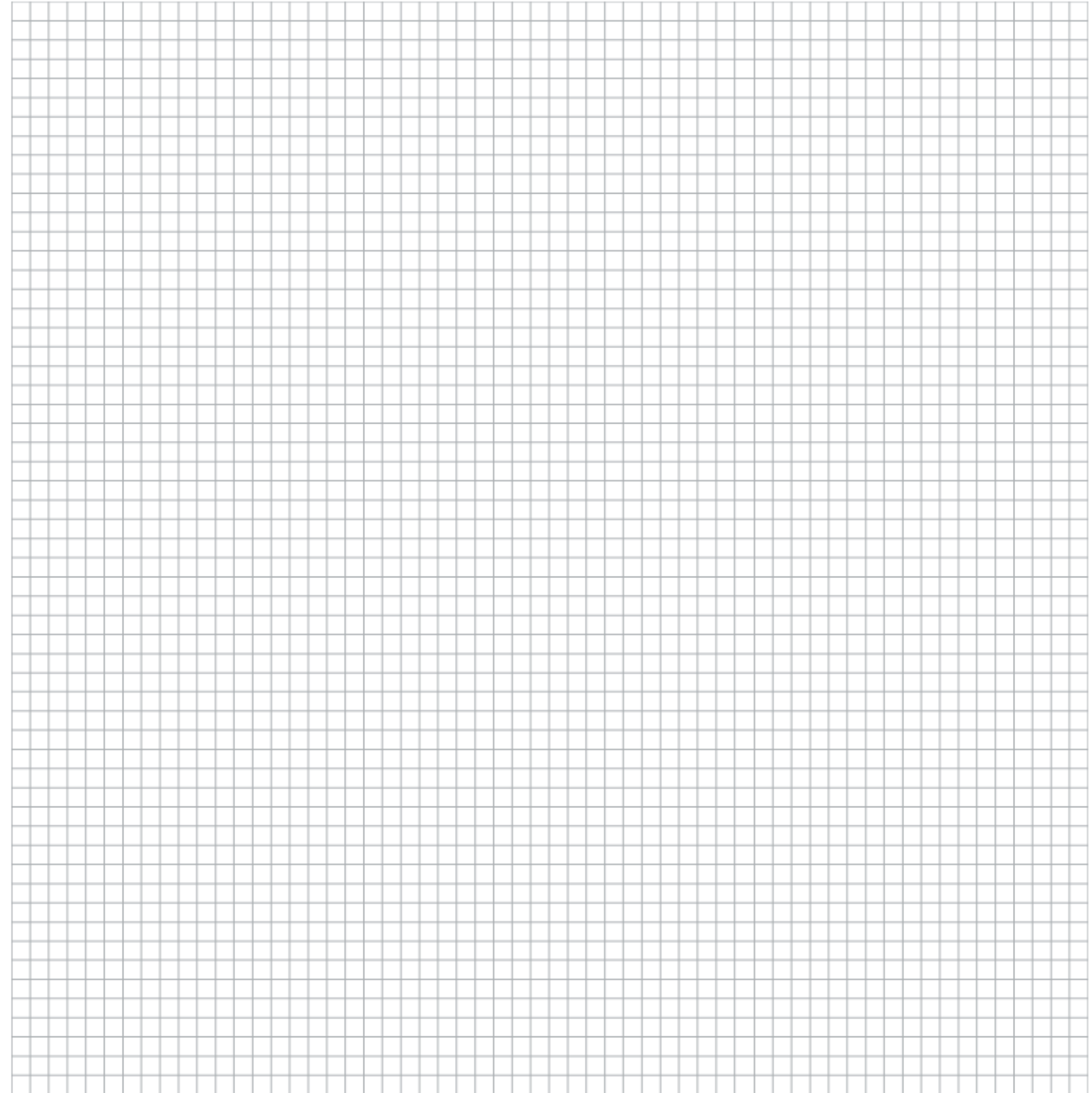

Grease Duct Field Sheet

Use Area to Sketch Rise, Run, and Estimated Design

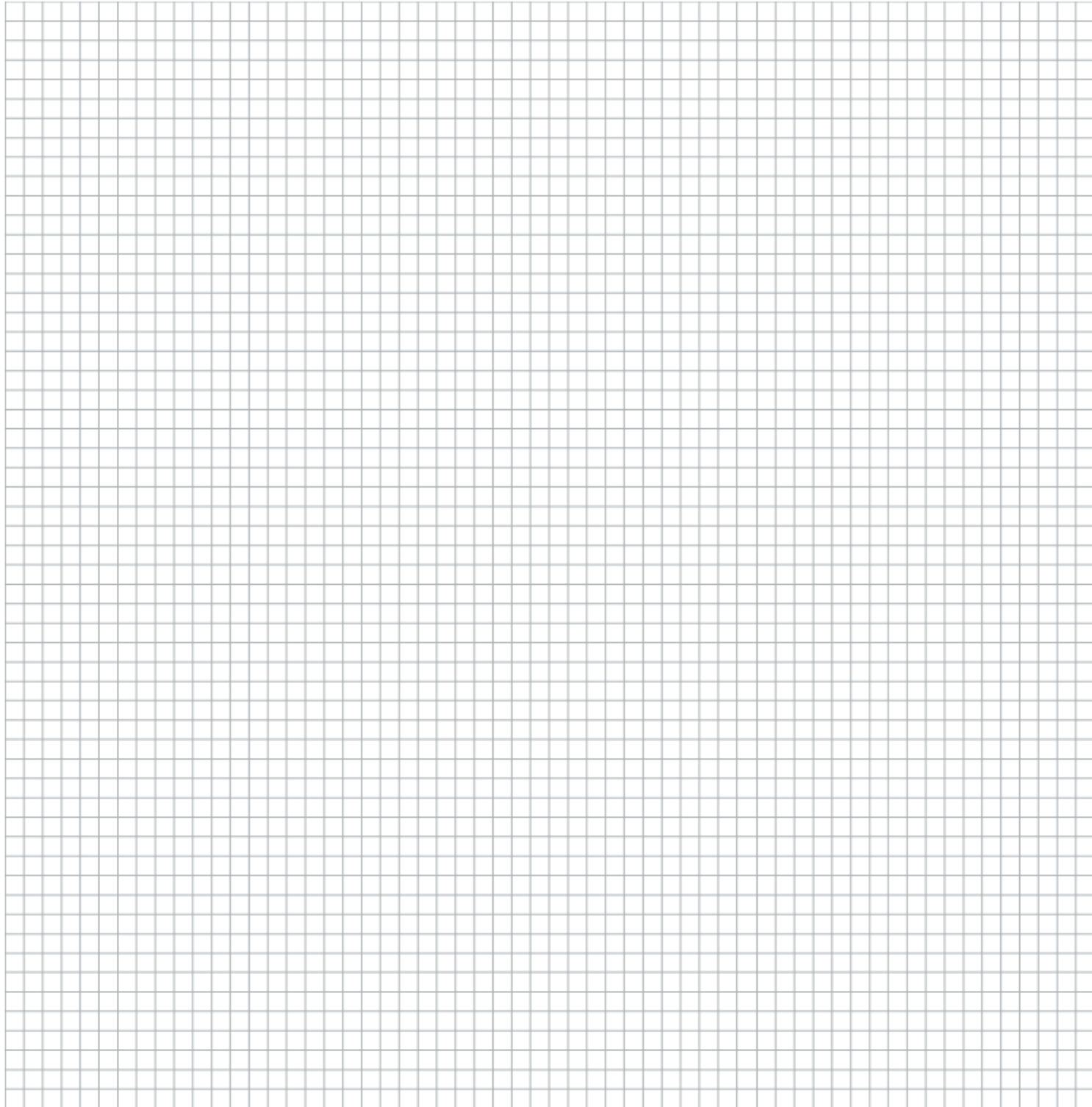

Grease Duct Field Sheet

Use Area to Sketch Rise, Run, and Estimated Design

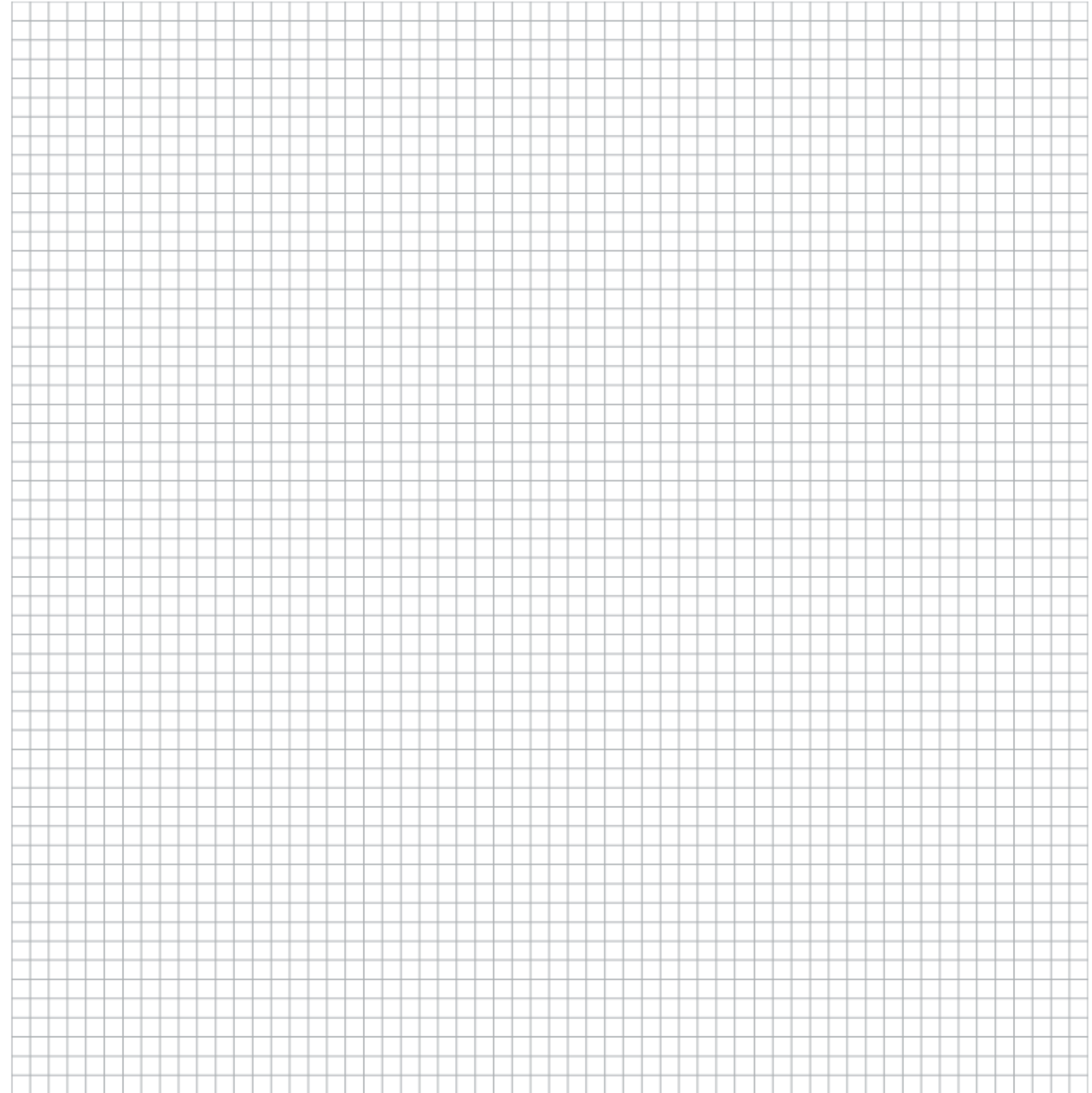

Grease Duct Field Sheet

Use Area to Sketch Rise, Run, and Estimated Design

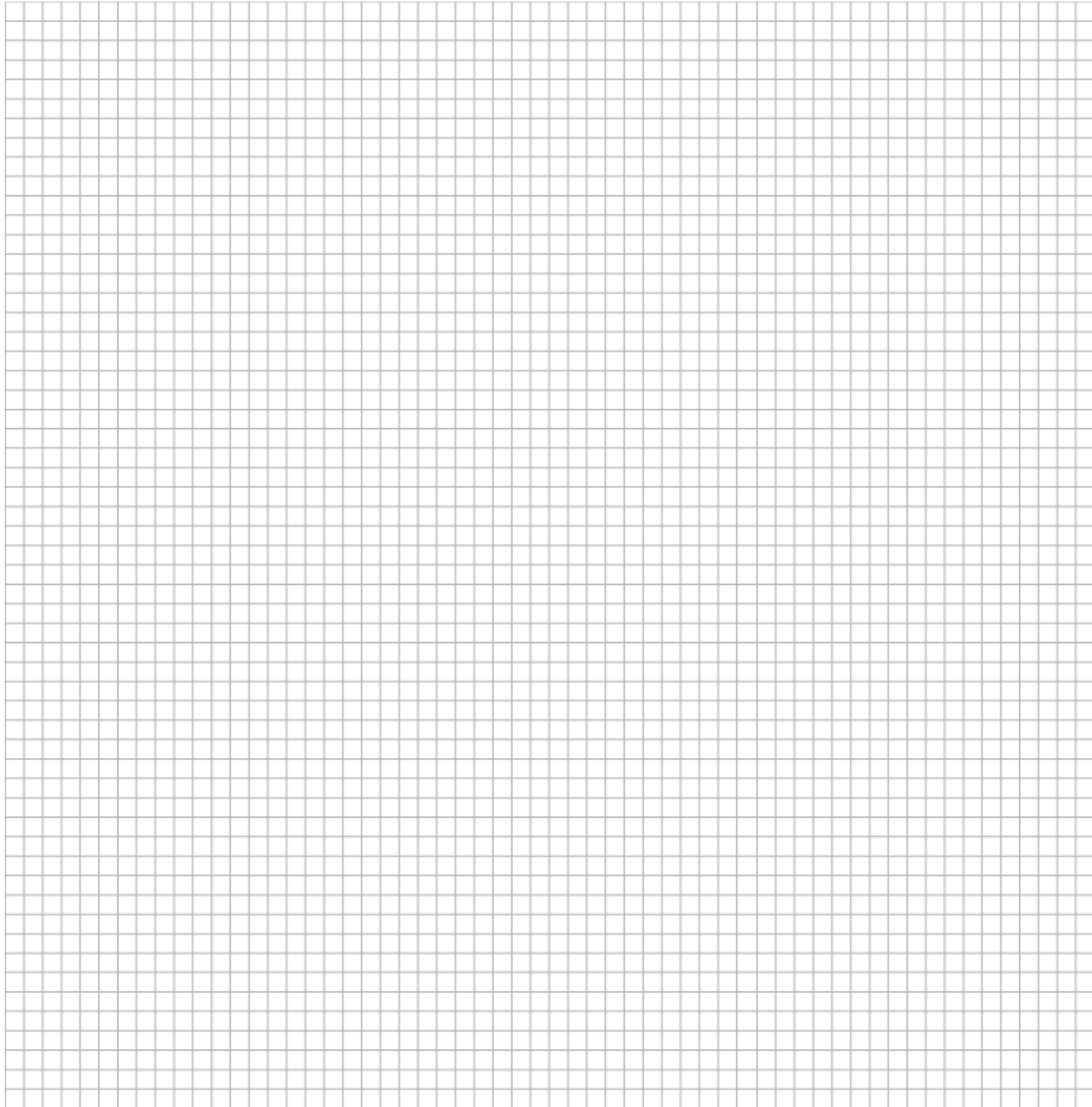

Grease Duct Field Sheet

Use Area to Sketch Rise, Run, and Estimated Design

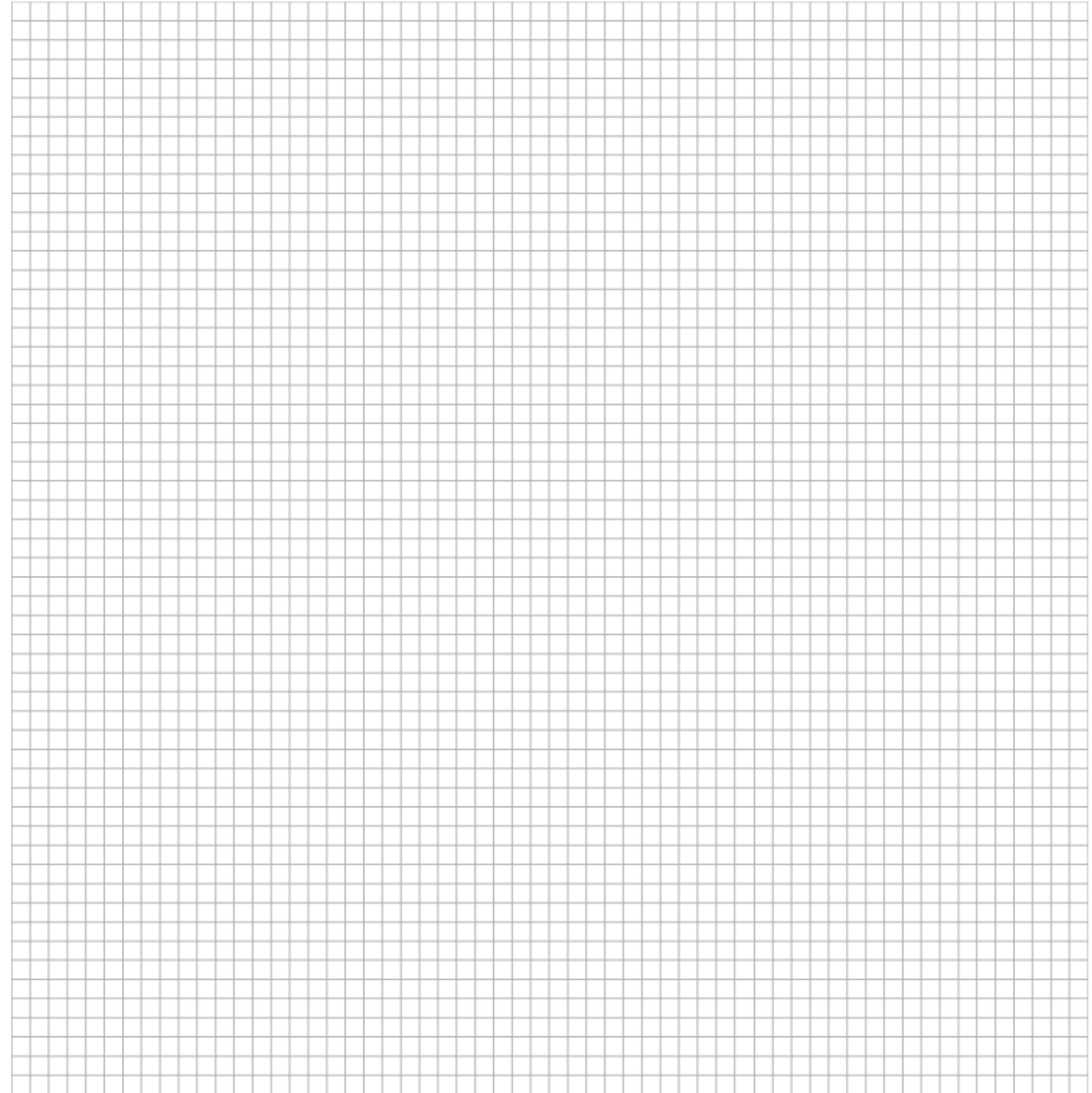



Toll-Free: 800.291.2452 | Phone: 952.435.0870 | Fax: 919.227.5959

17645 Juniper Path, Suite #150, Lakeville, MN 55044 | www.ruppams.com