

MODULAR OUTDOOR DOWN DISCHARGE BLOWER-ROOF TOP PACKAGE WITH LPD EVAPORATIVE COOLER AND INTAKE HOOD

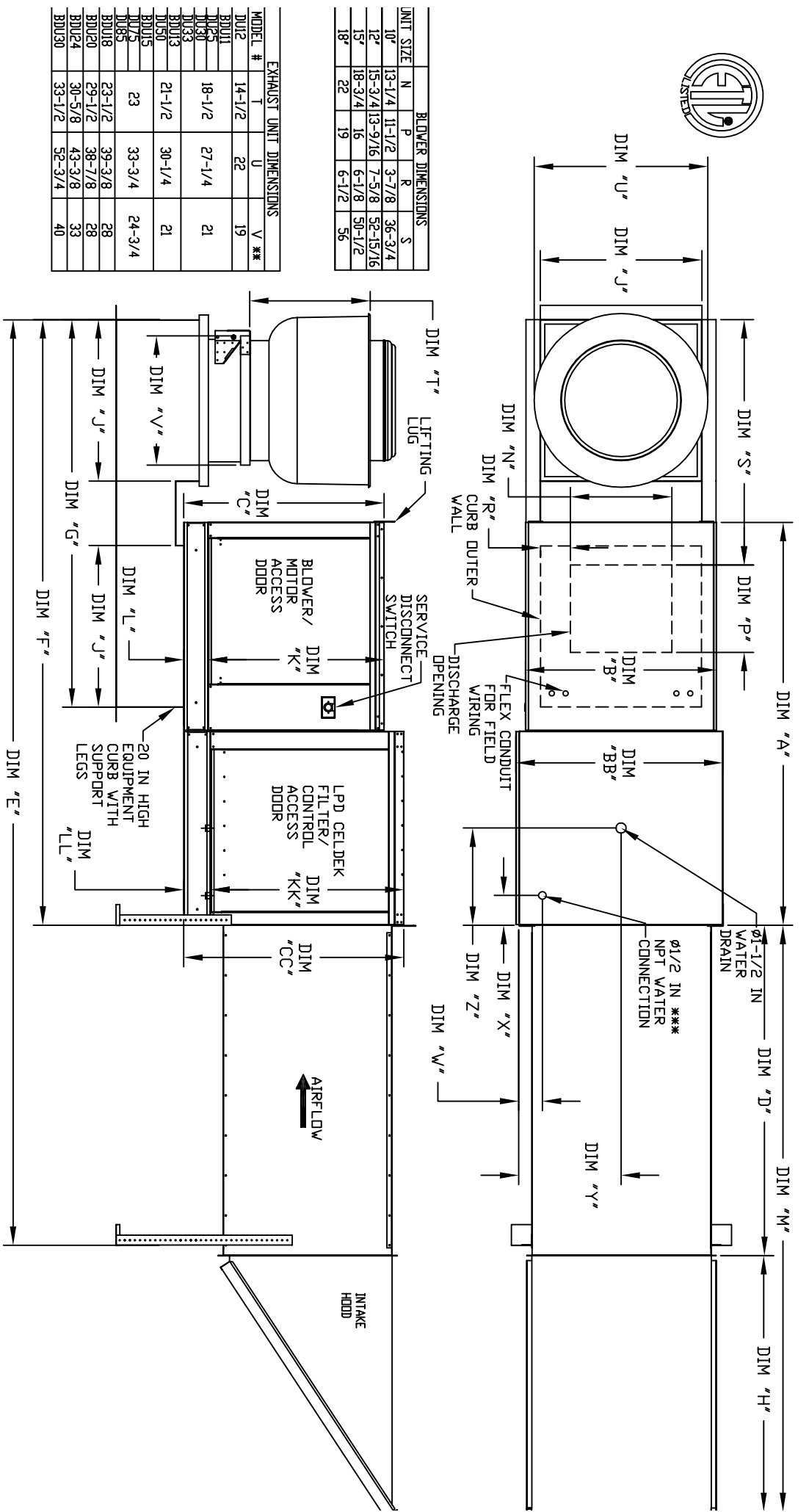

MODEL #	T	U	V ***
BDU2	14-1/2	22	19
BDU11			
BDU25	18-1/2	27-1/4	21
BDU30			
BDU33			
BDU33			
BDU50	21-1/2	30-1/4	21
BDU55			
BDU55			
BDU65	23	33-3/4	24-3/4
BDU85			
BDU88	23-1/2	39-3/8	28
BDU20	29-1/2	38-7/8	28
BDU24	30-5/8	43-3/8	33
BDU30	33-1/2	52-3/4	40

UNIT SIZE	N	P	R	S
10"	13-1/4	11-1/2	3-7/8	36-3/4
12"	15-3/4	13-9/16	7-5/8	52-15/16
15"	18-3/4	16	6-1/8	50-1/2
18"	22	19	6-1/2	56

SUPPLY UNIT DIMENSIONS												CURB AND RAIL DIMENSIONS												WATER INLETDRAIN OPENING												CELDEK EVAPORATIVE COOLING UNIT				EVAP. COOLING UNIT			
MODEL	A	B	BB	C	CC	D	E	F	G	H	J	K	KK	L	LL	M	V	X	Y	Z	WEIGHT	MEDIA SIZE & QTY	VEL. @ MAX. CFM	NOZZLES	MAX. FLOW RATE	WEIGHT	MEDIA SIZE & QTY	VEL. @ MAX. CFM	NOZZLES	MAX. FLOW RATE													
G10	64-1/4	27-3/8	27-3/8	29-3/4	29-3/4	80	171-11/16	99-3/4	56	53-5/8	21	66-1/8	33	3-3/4	3-3/4	133-5/8	1-7/8	6-1/4	18	16	620	25"x22"x12"	630 FPM	20	6.5 GPH	885	30"x36"x12"	667 FPM	28	8.4 GPH	895	30"x36"x12"	800 FPM	28	8.4 GPH	1255	38"x43"x12"	705 FPM	35	10.15 GPH			
G12	78-1/4	37-3/8	37-3/8	38-3/4	38-3/4	75	191-11/16	118-3/4	76	51-5/8	31	63-1/8	33	3-3/4	3-3/4	126-5/8	1-7/8	5-3/4	19	19																							
G15	78-1/4	37-3/8	37-3/8	36-3/4	36-3/4	75	191-11/16	118-3/4	76	51-5/8	31	63-1/8	33	3-3/4	3-3/4	126-5/8	1-7/8	5-3/4	20	19																							
G18	80-3/8	41-3/8	41-3/8	43-3/8	43-3/8	50	172-5/16	124-3/8	84	76-3/8	35	68-1/8	46	5-1/4	5-1/4	126-3/8	1-7/8	5-3/4	23-1/2	17-1/2																							

UNIT INFORMATION

MODEL FILTER SIZE & QTY MAX. FILTER VELOCITY

G10	20"x25"x2" (3)	83500 CFM = 406 FPM
G12	16"x20"x2" (6)	85000 CFM = 476 FPM
G15	16"x20"x2" (6)	86000 CFM = 571 FPM
G18	16"x20"x2" (10)	88000 CFM = 457 FPM

ROOF OPENING 2" SMALLER THEN CURB DIMENSION

*** 9 IN. HIGH EXHAUST ADAPTER MAY BE REQUIRED

*** MAY VARY BASED ON SPECIFIC - CONTACT ETI FOR DETAILS