

OUTDOOR DOWN DISCHARGE MOD PACKAGE UNIT, V-BANK, SCREEN INTAKE AND OPTIONAL MIXING BOX

SI/MBCCD4H-ME
REV#1 01/13/201



CONDENSER INFORMATION

MODEL	WEIGHT*	TONNAGE	CC	DD	EE
2 TON-1	119 LBS	2 TON	N/A	26-5/16	56-1/16
3 TON-1	134 LBS	3 TON	N/A	33-5/16	63-1/16
5 TON-1	253 LBS	5 TON	N/A	33-5/16	63-1/16
5 TON-1	302 LBS	5 TON	2.5TON	32-13/16	62-9/16
5 TON-1	197 LBS	5 TON	N/A	32-13/16	62-9/16
7.5 TON-2	348 LBS	2.5 TON	N/A	32-13/16	62-9/16
8 TON-2	331 LBS	3 TON	5 TON	33-5/16	71-11/16
10 TON-2	394 LBS	5 TON	5 TON	32-13/16	69-9/16
10 TON-3	394 LBS	5 TON	5 TON	32-13/16	76-3/16
10 TON-4	394 LBS	5 TON	5 TON	32-13/16	91-15/16

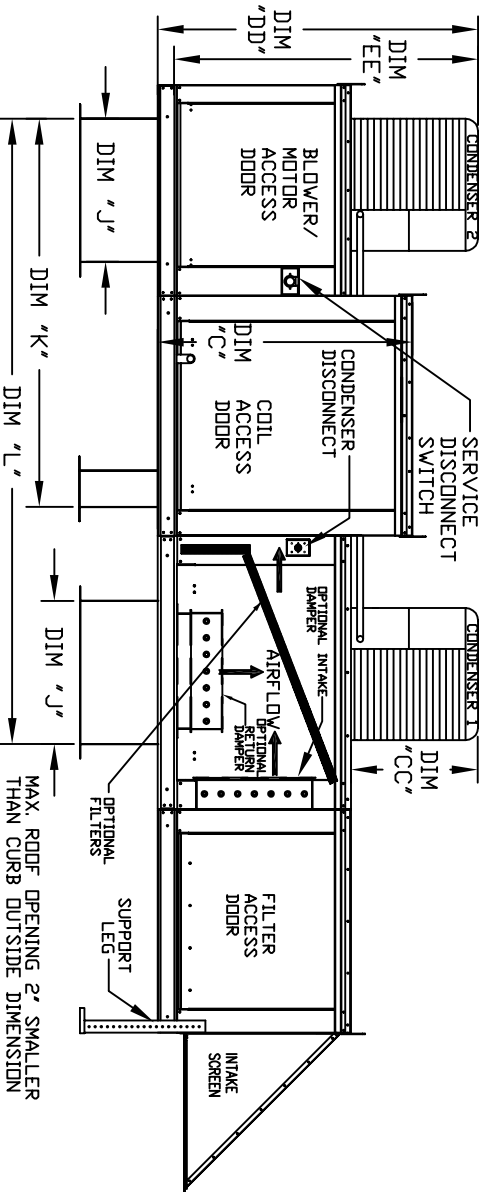
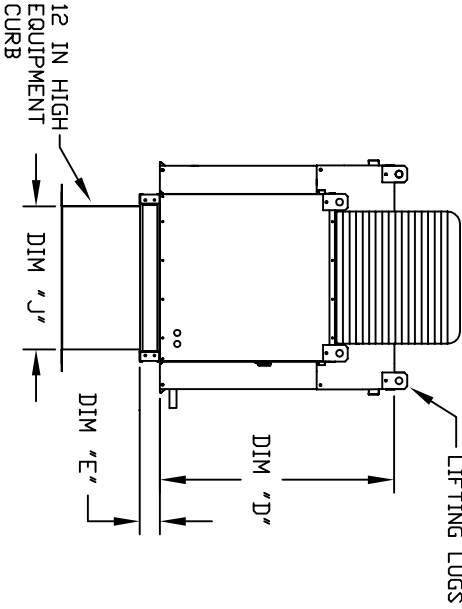
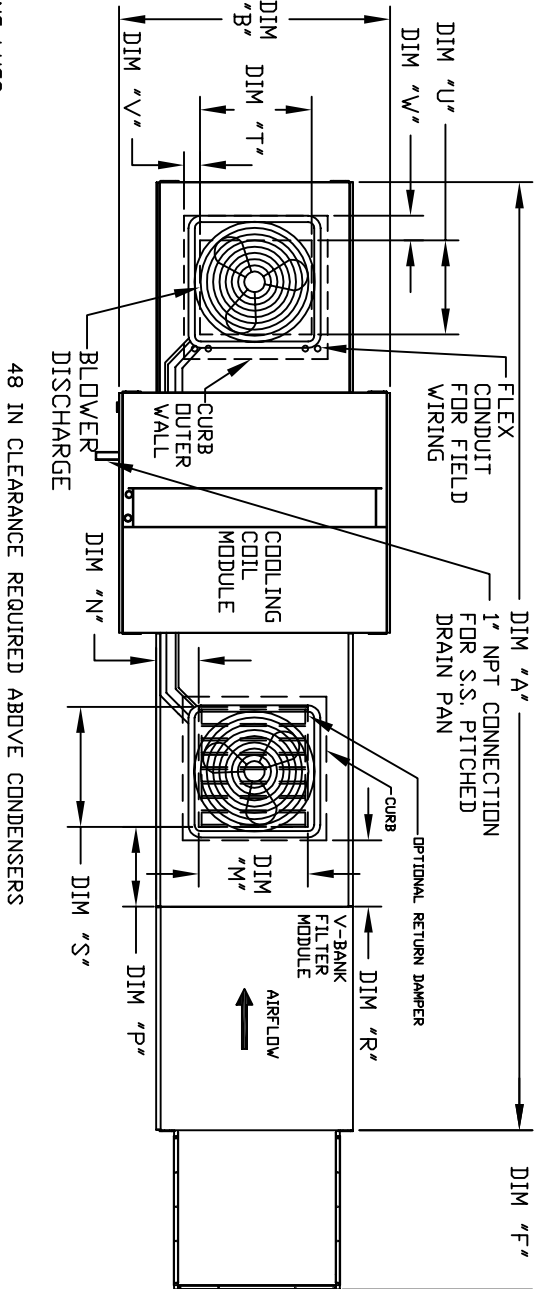

ALL DIMENSIONS ARE NOMINAL AND GIVEN IN INCHES.

UNIT SIZE	WEIGHT*	UNIT DIMENSIONS										RETURN OPENING		DISCHARGE OPENING		TONNAGE RANGE					
		A	B	C	D	E	F	J	K	L	M	N	P	R	S	T	U	V	MIN	MAX	
1	835 LBS	148-7/8	39-3/8	42-3/4	39	3-3/4	22-3/8	21	65-13/16	98-5/8	14	8	14	12-1/2	18	13-1/4	11-1/2	3-7/8	1-3/4	2	5 Ton
2**	1165 LBS	156-7/8	49-3/8	47-3/4	44	3-3/4	30-5/16	31	74-5/8	112-5/8	14	8	11	7-1/2	24	15-3/4	13-9/16	7-5/8	7-15/16	5	10 Ton
2	1175 LBS	156-7/8	49-3/8	47-3/4	44	3-3/4	30-5/16	31	74-5/8	112-5/8	14	8	11	7-1/2	24	15-3/4	13-9/16	7-5/8	7-15/16	5	10 Ton
3	1435 LBS	167-7/8	54-3/8	56-3/8	51-1/8	5-1/4	34-3/16	35	79-3/16	120-1/8	28	8	7	4-1/2	30	22	19	6-1/8	5-1/2	7	10 Ton
4	2325 LBS	208-3/16	60-7/16	64-3/8	59-1/8	5-1/4	47-1/4	42	104-9/32	153-15/16	33	10	11	8	36	24-7/8	24-7/8	8-9/16	1-1/8	10	10 Ton

UNIT INFORMATION

UNIT SIZE	FILTER SIZE & QTY	MAX. FILTER VELOCITY
1	20"x25"x2" (3)	3500 CFM = 406 FPM
2**	16"x20"x2" (8)	5000 CFM = 358 FPM
2	16"x20"x2" (8)	6000 CFM = 429 FPM
3	20"x25"x2" (8)	8000 CFM = 348 FPM
4	16"x20"x2" (15)	15000 CFM = 572 FPM

OPTIONAL MIXING BOX FILTERS

10"x16"x2" (3)
20"x25"x2" (2), 16"x25"x2" (1)
20"x25"x2" (2), 16"x25"x2" (1)
15"x20"x2" (4), 15"x15"x2" (2)
18"x25"x2" (4), 16"x20"x2" (2)

**ADD CONDENSING UNIT WEIGHT TO WEIGHT IN TABLE ABOVE
** DIMENSIONS APPLY TO UNITS WITH G12 BLOWERS ONLY

MAX. ROOF OPENING 2" SMALLER THAN CURB OUTSIDE DIMENSION