

MODULAR OUTDOOR DOWN DISCHARGE BLOWER WITH V-BANK, EVAPORATIVE COOLER, HEATING COIL, MIXING BOX AND INTAKE HOOD

INVENTORY#M
REV#1 11/1/2016

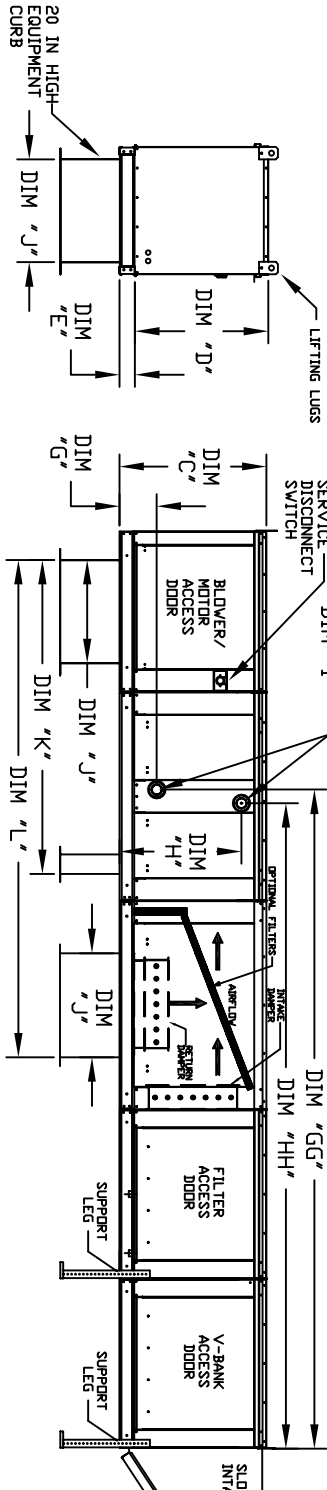
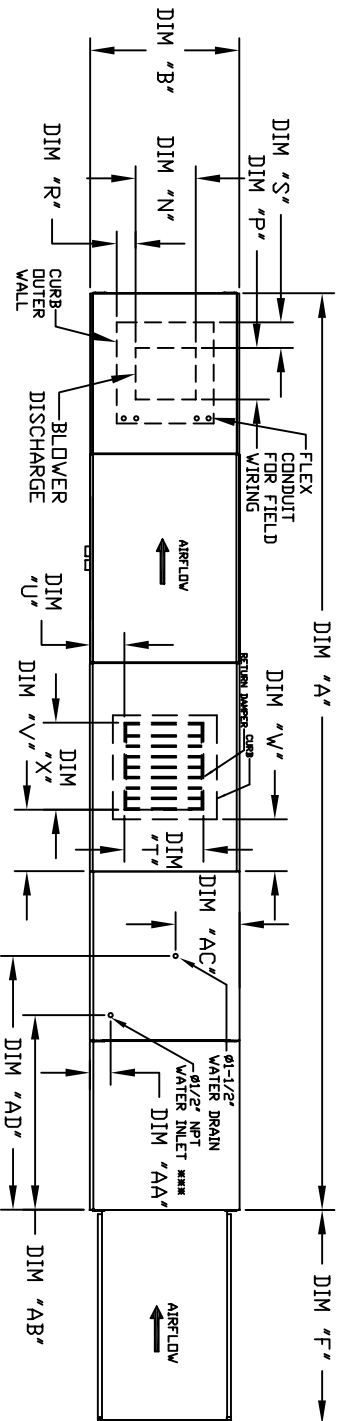

ALL DIMENSIONS ARE NOMINAL AND GIVEN IN INCHES.

UNIT SIZE	1	2**	3	4	5
FILTER SIZE & QTY	10"x16"x2" (5)	20"x25"x2" (2), 16"x25"x2" (1)	20"x25"x2" (2), 16"x25"x2" (1)	15"x20"x2" (4), 15"x15"x2" (2)	18"x25"x2" (4), 16"x20"x2" (2)
WATER INLET DRAIN OPENING	14.5"x19"x2" (12)				
V-BANK FILTER					

UNIT SIZE	HOT WATER COIL MODULE													STEAM COIL MODULE												
	A	B	C	D	E	F	G	H	I	J	K	L	T	U	V	W	X	N	P	R	S	AA	AB	AC	AD	AE
1	191-1/8	27-3/8	29-3/4	26-1/16	13-3/4	44-3/8	21	65-13/16	98-5/8	14	8	14	12-1/2	18	13-1/4	11-1/2	3-7/8	1-3/4	4-1/2	138-1/2	13	48-1/4	20"x25"x2" (3)			
2**	199-1/8	37-3/8	36-3/4	33-1/16	13-3/4	53-5/8	31	74-5/8	112-9/16	22-3/4	8	11	7-1/2	24	15-3/4	13-9/16	7-5/8	7-15/16	4-1/2	138-1/2	18	48-1/4	16"x20"x2" (8)			
3	199-1/8	37-3/8	36-3/4	33-1/16	13-3/4	53-5/8	31	74-5/8	112-9/16	22-3/4	8	11	7-1/2	24	15-3/4	13-9/16	7-5/8	7-15/16	4-1/2	138-1/2	18	48-1/4	16"x20"x2" (8)			
4	210-1/8	41-3/8	43-3/8	38-1/16	5-1/4	51-5/8	35	79-3/16	120-1/8	28	8	7	4-1/2	30	22	19	6-1/2	7	4-1/2	144	20	57-1/4	20"x25"x2" (8)			
5	262-1/8	248-7/16	51-3/8	46-1/8	5-1/4	76-3/8	42	104-9/32	153-15/16	33	10	11	8	36	24-7/8	24-7/8	8-9/16	1-1/8	4-1/2	141-1/8	23-1/2	52-7/8	15"x20"x2" (15)			
	272-1/2	259-3/16	58-3/8	53-1/8	5-1/4	71-3/8	52-3/4	114-21/32	170-7/8	43	106-1/2	121-1/4	43	31	3-7/8	10-11/16	13-13/16	4-1/2	141-1/8	28-7/8	52-7/8	20"x25"x2" (12)				
HOT WATER COIL MODULE		STEAM COIL MODULE		TOTAL CAPACITY PIPE CONNECTION		TOTAL CAPACITY PIPE CONNECTION		TOTAL CAPACITY PIPE CONNECTION		TOTAL CAPACITY PIPE CONNECTION		TOTAL CAPACITY PIPE CONNECTION		TOTAL CAPACITY PIPE CONNECTION		TOTAL CAPACITY PIPE CONNECTION		TOTAL CAPACITY PIPE CONNECTION		TOTAL CAPACITY PIPE CONNECTION		TOTAL CAPACITY PIPE CONNECTION		TOTAL CAPACITY PIPE CONNECTION		
UNIT SIZE	(KWH)	G (GPH)	G (GPH)	G (GPH)	G (GPH)	G (GPH)	G (GPH)	G (GPH)	G (GPH)	G (GPH)	G (GPH)	G (GPH)	G (GPH)	G (GPH)	G (GPH)	G (GPH)	G (GPH)	G (GPH)	G (GPH)	G (GPH)	G (GPH)	G (GPH)	G (GPH)	G (GPH)	G (GPH)	
1	165.63	2	8-1/4	129-3/16	24-3/4	4126-7/16	HH	1	176.49	1/16	49	2-1/2	5	8-3/4	127-13/16	16-15/16	127-13/16	HH	16"x20"x2" (3)	3500 CFM = 667 FPM	12	3.9 GPH				
2**	320.88	2	8-1/4	129-3/16	28-3/4	4126-7/16	2**	328.19	3/8	19	2-1/2	5	8-3/4	127-13/16	18-3/8	127-13/16	HH	20"x25"x2" (3)	3500 CFM = 580 FPM	20	6.5 GPH					
3	514.97	2	8-1/4	129-3/16	28-3/4	4126-7/16	2	505.64	3	505.64	2-1/2	5	10-1/4	139-13/16	23-5/8	139-13/16	HH	20"x25"x2" (3)	3500 CFM = 696 FPM	20	6.5 GPH					
4	831.87	2-1/2	10	153-5/8	45-1/2	2150	4	812.24	4	812.24	2-1/2	5	10-1/4	139-13/16	23-5/8	139-13/16	HH	16"x20"x2" (6)	3500 CFM = 762 FPM	28	8.4 GPH					
5	1230.16	3	10-1/4	153-7/8	52-1/4	1530-3/8	5	1234.45	5	1234.45	2-1/2	5	10-1/4	152-3/16	31-3/4	152-3/16	HH	20"x25"x2" (8)	3500 CFM = 857 FPM	35	10.15 GPH					

** DIMENSIONS APPLY TO UNITS WITH G12 BLOWERS ONLY
*** MAY VARY WATER DIRECTION - EN DET A 70 NERR C